

Manual 2025 Rev C p/n 002025 0000

WARNING! Read and understand operator's manual before using this equipment. Failure to follow operating instructions could result in injury or damage to the equipment.



EX ATEX Series OPERATOR'S MANUAL

Models

| | | | |
|--------|--------|--------|--------|
| EX3204 | EX4009 | EX5507 | EX5518 |
| EX3206 | EX4012 | EX5511 | EX5524 |
| EX3210 | | EX5514 | |

ATEX EX Double Envelope Gastight Bare
Shaft Blowers, Vacuum Boosters, and
C-Flange Vacuum Boosters

OPERATION &
MAINTENANCE MANUAL
FOR EQUIPMENT IN
HAZARDOUS AREAS IN
ACCORDANCE WITH THE
ATEX DIRECTIVE



Disclaimer Statement:

All information, illustrations and specifications in this manual are based on the latest information available at the time of publishing. The illustrations used in this manual are intended as representative reference views only. Products are under a continuous improvement policy. Thus, information, illustrations and/or specifications to explain and or exemplify a product, service or maintenance improvement may be changed at any time without notice.

Rights Reserved Statement:

No part of this publication may be reproduced or used in any form by any means - graphic, electronic or mechanical, including photocopying, recording, taping or information storage and retrieval systems - without the written permission of M-D Pneumatics®.

Product information and specifications subject to change.

Table of Contents

| | |
|---------------------------------------------|-----------|
| Introduction | 1 |
| Scope of Manual..... | 1 |
| Hazardous Area Definition | 1 |
| Safety X Devices | 1 |
| Safety Devices | 2 |
| Explosion Triangle | 3 |
| Equipment/Process Data | 5 |
| Conventions and Data Plate | 8 |
| Graphic Conventions in this Manual | 8 |
| Nameplate Markings and Identification | 9 |
| ATEX Classification Marking Sample | 9 |
| Lifting | 12 |
| Description | 13 |
| Flow By Direction | 14 |
| Blower Operating Limits (Stand Alone)..... | 16 |
| Installation | 17 |
| General | 17 |
| Vacuum Gauges and Switches | 18 |
| Foundation..... | 18 |

| | |
|-----------------------------------------------------------------------|-----------|
| Location..... | 18 |
| Piping Connections..... | 19 |
| Port Fitting Loading..... | 20 |
| Blower Air Intake | 21 |
| Soft Foot | 21 |
| Safety | 22 |
| Recommended Lubricants for Blowers and Vacuum Boosters..... | 23 |
| For Oxygen-Enriched Service | 23 |
| Frequently Asked Questions Regarding Lubrication | 25 |
| Hazards Associated with Breakdown or Ignition of Lubrication | 26 |
| Hazards Associated with Hazardous Process Fluids | 26 |
| Blockage or Restriction | 26 |
| Cooling Coils | 27 |
| Motor Drives | 28 |
| Direct-Coupled Drive..... | 28 |
| V-Belts | 28 |
| Motor and Electrical Connections By Others | 29 |
| Operation | 30 |
| General | 30 |
| Blower | 30 |
| Start-Up Checklist..... | 31 |
| Starting a Vacuum Booster | 32 |
| Operating | 32 |

Recommended Shutdown Procedure to Minimize Risk of Freezing or Corrosion 33

Long-Term Storage 34

Maintenance 35

 General 35

 Regular Maintenance 35

 Spare Parts - Only Sold to Authorized Service Centers 36

 Factory Service and Repair 37

 Maintenance..... 37

 Responsibilities and Warranty 38

Troubleshooting 39

Assembly Clearances 41

Torque Chart..... 42

Parts List and Assembly Drawings 43

 Model EX3200 - Double Envelope 43

 Model EX3200 - Double Envelope - Dimensions 45

 Parts List for Model EX3200 - Double Envelope 46

 Model EX3200 - Double Envelope - C-flange 47

 Model EX3200 - Double Envelope - C-flange - Dimensions 49

 Parts List for Model EX3200 - Double Envelope - C-flange 50

 Model EX4000 - Double Envelope 51

 Model EX4000 - Double Envelope - Dimensions 53

 Parts List for Model EX4000 - Double Envelope 54

 Model EX4000 - Double Envelope - C-flange 55

 Model EX4000 - Double Envelope - C-flange - Dimensions 57

 Parts List for Model EX4000 - Double Envelope - C-flange 58

Table of Contents

Model EX5500 - Double Envelope 59

Model EX5500 - Double Envelope - Dimensions 61

Parts List for Model EX5500 - Double Envelope 62

Model EX5500 - Double Envelope - C-flange 63

Model EX5500 - Double Envelope - C-flange - Dimensions 65

Parts List for Model EX5500 - Double Envelope - C-flange 66

C-Flange Vacuum Booster Motor Adapter Kit (NEMA
for EX5500 Series Only 67

C-Flange Vacuum Booster Motor Adapter Kit (IEC)
for EX5500 Series Only 68

Warranty - Blower Products..... 69

Operating Data Form / Product Registration.....70

SCOPE OF MANUAL

The scope of this manual includes the ATEX EX3200, EX4000, and EX5500 series bare shaft and C-flange rotary positive displacement units.

HAZARDOUS AREA DEFINITION

A hazardous area is defined as an area in which potential or existing explosive atmospheres are present in quantities that require special precaution for the construction and use of equipment. An explosive atmosphere consists of a mixture of flammable substances with air in the form of gas, vapor, or mist, in such proportions that it can be exploded by excessive temperatures, arcs, or sparks. The ATEX EX3200, EX4000, and EX5500 series units to perform as required in this environment. However, the installation methods, safety devices (listed below), and use of VBXpert Portal design software utilizing the built-in conditions of service are all required to meet the ATEX Directive 2014/34/EU.

SAFETY X DEVICES

See Table 1-1 on page 2.

All equipment and instrumentation must comply with ATEX Directive and the associated area classification. In order to enhance the safe operation of the unit, it is necessary to install the following safety devices. Some of these devices will also help monitor the operational conditions

and can be used to either alarm or isolate the equipment if the equipment operates outside what is permitted. The devices below are a non-exclusive list and can be either a switch or transmitter device where applicable.

The safety equipment is designed and selected to meet the requirements of particular gas groups and the zone according to the ATEX Directive. At the time of order the units will have been selected with knowledge of the gases being united. If the unit(s) are later moved to a different process or are subjected to alternate mediums, then the factory must be consulted, and written acceptance received before transferring the unit(s) or starting them up. M-D Pneumatics does not accept liability for the use of the equipment in hazardous areas other than that for which it was originally specified at the time of order.

In all instances where a safety switch or protective device is fitted, it should stop the unit in the case of CAT2 and alarm as a minimum for CAT3. It is also necessary to include an emergency stop button which when activated cuts the power to the system and which then requires a manual reset and independent start function to restart the equipment for all cases.

Introduction

Safety Devices

All equipment and instrumentation must comply with ATEX and the associated area classification.

For enhanced safe operation of the unit, it is necessary to install the following required safety devices.

Some of these devices will also help monitor the operational conditions and can be used to either alarm or isolate the equipment if the equipment operates outside that permitted.

The list of devices below is non-exclusive and can comprise either a switch or transmitter device where applicable.

| Monitoring Location | Description | Qty | Port Sizes/ Type | Equipment Category | | |
|---------------------------|-------------------------------------------------------------------------------------------------------------------------------------------------------------------------------------------------------------------------------------------------------------------------------------------------------------------------------------------------------------------------------------------------------------------------------|-----|------------------------------------------------------------------------------------------------|--------------------|-------------|------------|
| | | | | Category 1 | Category 2 | Category 3 |
| Bearing Vibration | Each bearing has a drilled port for a vibration sensor that is located on the top of the end plate. Each end plate has 2 locations (1 for each bearing). Continuous monitoring provides data that will show early bearing failure. | 4 | 1/4"-28UNF-2B WITH 7/8" SPOT FACE | N/A | Optional | Optional |
| Inlet Temperature | Fitted to the inlet suction manifold, the device would be set at a pre-determined set point so that, in the event of high inlet temperature, it would force an alarm condition. | 1 | 1 is 1/2" NPT 1 is 1/4" NPT | N/A | Optional | Optional |
| Oil Temperature | Oil temperature is a factor of the operating conditions and is a result of proper water-cooling. A temperature switch or sensing device could be fitted in the oil sump holes located opposite the sight glasses. Oil temperature should never exceed 177°C (350°F) (1 switch required per oil sump). | 1 | Oil sump hole is 1/8" NPT Oil drain hole is 3/8" NPT (EX3200 & EX4000) 1/2" NPT (EX5500) | N/A | Required b1 | Optional |
| Oil Level | As standard, the units are fitted with sight glasses or oil level plugs and should be kept at the full level for the device on each oil sump. One level sensor can be located in the bottom hole of each cover (opposite sight glass) to alert for low oil. | 1 | 1/8" NPT | N/A | Optional | Optional |
| Cooling Water Flow | Fitted to the water-cooling outlet connection, it measures and detects in the event of low flow. The device should alarm if the cooling water flow falls below the set point [1.9- 3.8 L/min (0.5-1.0 GPM)] | 2 | 1/8" NPT | N/A | Optional | Optional |
| Cooling Water Temperature | Fitted to the water inlet connection, it would monitor the water-cooling supply temperature and alarm if it increased beyond that permitted. Min water temp 1°C (33°F) | 1 | 1/8" NPT | N/A | Optional | Optional |
| Blower Discharge Pressure | In the event that the exhaust line of the unit becomes blocked, restricted or sees elevated levels outside that of the design, a device such as a pressure switch is fitted to detect so that the unit can be tripped or an alarm raised if pressure exceeds pressures approved for unit in VBX Portal conditions of service and submitted with PO. Without this detail, the max differential pressure is .689 bar (10 PSIG). | 1 | 1/2" NPT | N/A | Optional | Optional |
| Inlet Filter Gauge | Fitted to the inlet filter (where applicable, provided and installed by others) to monitor differential pressure and detect if the filter element becomes blocked. As standard, a filter restriction gauge would be fitted for local indication. A switch could also be fitted for relaying this signal back to control system for alarm purposes. | 1 | By Others | N/A | Optional | Optional |
| Discharge Temperature | Fitted to the outlet pipe of the unit, it would monitor and detect in the event that the gas temperature increased and eventually exceeded the max. allowable discharge temperature of 177°C (350°F), which would shut off the unit. | 1 | 1/4" NPT | N/A | Required b1 | Optional |
| Differential Pressure | Fitted to the unit, the device would monitor for differential pressure and alarm – trip if the max. allowable range is exceeded. | 1 | 1 is 1/2" NPT 1 is 1/4" NPT | N/A | Optional | Optional |
| Pressure Relief Valve | Fitted to the outlet line of the unit, the device would relieve at a pre-determined set point to prevent over-pressure operation of the equipment by limiting the discharge pressure. | 1 | By Others | N/A | Optional | Optional |

Table 1-1 – X Devices Matrix (See Section 6.5 of ISO 80079-37 for b1 standard)

Also See Figure 1-2 on page 4

Definitions:

A **FLAMMABLE gas** by definition is a gas that does NOT have oxygen present sufficient to support combustion.

An **EXPLOSIVE gas** by definition is a gas that DOES have oxygen present sufficient to support combustion.

DANGER

Fire/Explosion Hazard

The blower or booster is intended to internally handle explosive gas mixtures up to the critical gas combustion pressure of approximately 100 mbar. This pressure varies by gas type. All product selections are required to be evaluated through the VBXpert Portal sizing software prior to quotation. For pressures greater than 100 mbar ATEX Internal classification is not supported.

EXPLOSION TRIANGLE

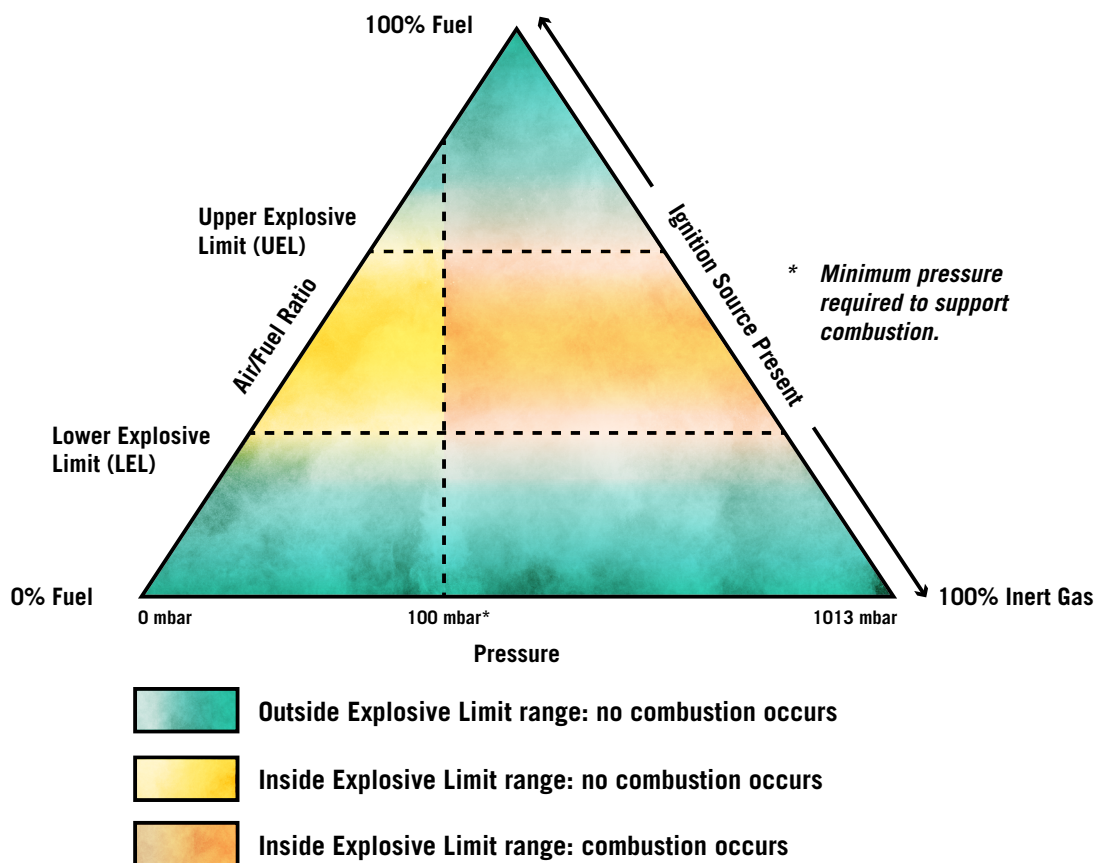

Figure 1-1 – Explosion Triangle

Introduction

Example Operation & Usage for Boosters in Hazardous Areas

Equipment type: Rotary Lobe Mechanical Vacuum Booster

Manufacturer Type: EX3200, EX4000, and EX5500 ATEX Series

The equipment must be handled, installed and the system set up by a competent person so that it operates within the guidelines provided. Some values on the right may vary depending on the operating conditions with the exception that TS3 values must remain as stated.

- A Mechanical vacuum booster (EX3200, EX4000, and EX5500)
- B Backing pump
- TS1 Process gas temperature switch (set to trip at 122°F [50°C] rising)
- PS Process inlet pressure switch (set at 20 Torr [20 mmHg] for control of booster starting)
- TS2 Water-cooling feed temperature switch (set to alarm at 86°F [30°C] rising)
- FS Water-cooling return flow switch (set to alarm at less than 1.5 l/min)
- TS3 Booster discharge gas temperature switch (set to trip at 177°C [350°F] rising)

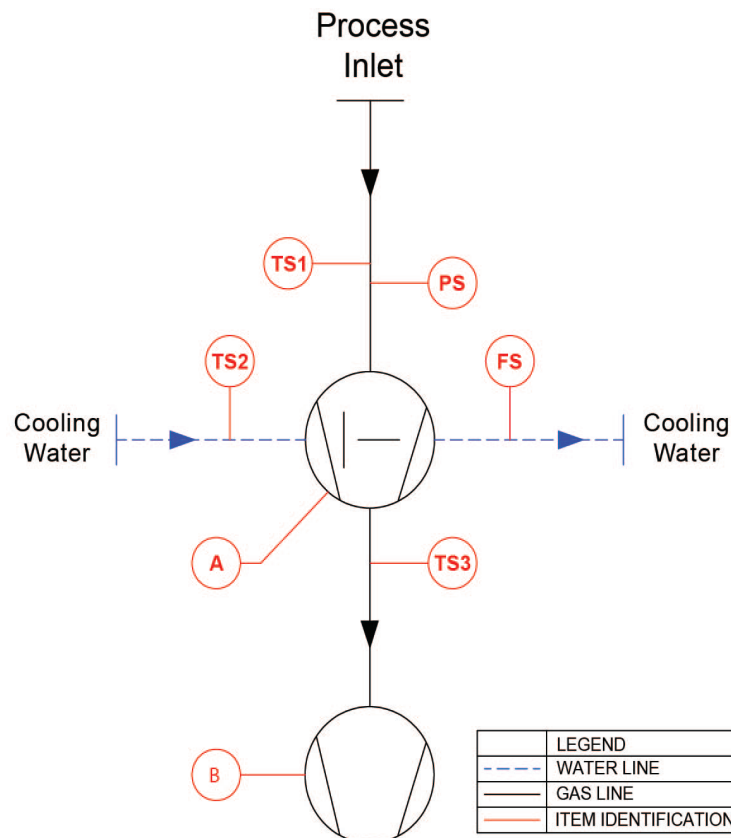

Figure 1-2 – System Arrangement
Also See Table 1-1 on page 2

EQUIPMENT/PROCESS DATA

Starting procedure:

1. Turn on the cooling water supply.
2. Start the backing pump.
3. Start the booster via the pressure switch (PS).

Stopping procedure:

1. Stop the booster.
2. After 20 seconds stop the backing pump.
3. Turn off the cooling water supply.

NOTICE

If any switch activates or deactivates, the system should either alarm or trip as stated. Always address and resolve the problem before continuing to use the equipment.

| | |
|--------------------------------|--------------------------------------------|
| Maximum rotational speed (rpm) | 3600 |
| Minimum rotational speed (rpm) | 1150 |
| Process cleanliness | Clean (free from debris or process medium) |
| External Classification | CE EX II 2 G Ex h IIB H2 T3 Gb X |

Booster with Backing Pump Parameters

| | Nominal Displacement | | | | Max Pressure Differential across booster* | | | | Motor Power | | | |
|---------------|----------------------|------|----------------|------|-------------------------------------------|-------|----------------|-------|----------------|------|----------------|------|
| | 50 Hz-3000 RPM | | 60 Hz-3600 RPM | | 50 Hz-3000 RPM | | 60 Hz-3600 RPM | | 50 Hz-3000 RPM | | 60 Hz-3600 RPM | |
| | m3/hr | cfm | m3/hr | cfm | mbar | Torr | mbar | Torr | kW | HP | kW | HP |
| EX3204 | 212 | 125 | 255 | 150 | 0-169 | 0-127 | 0-173 | 0-130 | 2.5 | 3.3 | 3.0 | 4.0 |
| EX3206 | 338 | 199 | 408 | 240 | 0-169 | 0-127 | 0-173 | 0-130 | 2.9 | 3.9 | 3.6 | 4.8 |
| EX3210 | 564 | 332 | 680 | 400 | 0-169 | 0-127 | 0-173 | 0-130 | 4.0 | 5.3 | 4.8 | 6.5 |
| EX4009 | 761 | 448 | 917 | 540 | 0-197 | 0-148 | 0-200 | 0-150 | 5.7 | 7.7 | 6.9 | 9.3 |
| EX4012 | 1015 | 598 | 1223 | 720 | 0-197 | 0-148 | 0-200 | 0-150 | 7.1 | 9.5 | 8.7 | 11.6 |
| EX5507 | 1206 | 710 | 1444 | 850 | 0-85 | 0-64 | 0-87 | 0-65 | 5.1 | 6.8 | 6.1 | 8.2 |
| EX5511 | 1699 | 1000 | 2039 | 1200 | 0-85 | 0-64 | 0-87 | 0-65 | 6.4 | 8.6 | 7.8 | 10.4 |
| EX5514 | 2209 | 1300 | 2718 | 1600 | 0-85 | 0-64 | 0-87 | 0-65 | 7.5 | 10.1 | 9.2 | 12.3 |
| EX5518 | 2829 | 1665 | 3398 | 2000 | 0-85 | 0-64 | 0-87 | 0-65 | 9.0 | 12.1 | 11.0 | 14.8 |
| EX5524 | 3823 | 2250 | 4587 | 2700 | 0-85 | 0-64 | 0-87 | 0-65 | 11.1 | 14.9 | 13.5 | 18.1 |

* For air at 20C (68F) inlet temp, 75 torr (100 mbar) inlet pressure.

NOTE: Use VBXpert Portal sizing software for other conditions

Table 1-2 – Equipment/Process Data

| Model | Min RPM | Max RPM | m3/h (cfm) |
|--------|---------|---------|----------------------|
| EX3204 | 1150 | 3600 | 81-255 (48-150) |
| EX3206 | 1150 | 3600 | 130-408 (77-240) |
| EX3210 | 1150 | 3600 | 217-680 (128-400) |
| EX4009 | 1150 | 3600 | 293-918 (173-540) |
| EX4012 | 1150 | 3600 | 391-1224 (230-720) |
| EX5507 | 1150 | 3600 | 459-1445 (270-850) |
| EX5511 | 1150 | 3600 | 680-2107 (400-1240) |
| EX5514 | 1150 | 3600 | 850-2719 (500-1600) |
| EX5518 | 1150 | 3600 | 1105-3399 (650-2000) |
| EX5524 | 1150 | 3600 | 1445-4588 (850-2700) |

Table 1-2 – Equipment/Process Data (Continued)

Units that are expected to operate with a discharge gas temperature of greater than 248°F (120°C) should be piped with cooling water in order to maintain oil temperatures.

It is necessary to ensure that the units do not see any process carryover or debris. Suitable filtration should be fitted in instances where it is thought that carryover or debris may occur.

A commissioning filter should also be used on initial start-ups to prevent entry of foreign bodies entering the pump while the process piping is open or during pipework adjustments.

The booster should not be allowed to windmill for prolonged periods of time. In the event that long evacuation times are anticipated then a bypass line and valve arrangement should be used around the booster.

Operation of the equipment under conditions that differ from when the order was received and/or outlined above must first be authorized by the factory.

**DANGER****Fire/Explosion Hazard**

Do not use the blower in applications that include hazardous and toxic gases.

The blower or booster is intended to internally handle explosive gas mixtures up to the critical gas combustion pressure of approximately 100 mbar. This pressure varies by gas type. All product selections are required to be evaluated through the VBXpert Portal sizing software prior to quotation. For pressures greater than 100 mbar ATEX Internal classification is not supported.

Definition of Hazardous Gas: A gas that has an NFPA Health Class rating of 4 or a GHS Health rating of 1.

1. A **FLAMMABLE gas** by definition is a gas that does NOT have oxygen present sufficient to combustion. This is what we authorize our blowers to handle.
2. An **EXPLOSIVE gas** by definition is a gas that DOES have oxygen present sufficient to combustion. We do NOT authorize our blowers to handle this gas.

CONGRATULATIONS on the purchase of a new **ATEX EX Rotary Positive Displacement Unit**. Please examine the unit for shipping damage, and if any damage is found, report it immediately to the carrier. If the unit is to be installed at a later date, make sure it is stored in a clean, dry location and rotated regularly. Make sure covers are kept on all openings. If the unit is stored outdoors, be sure to protect it from weather and corrosion.

ATEX EX units are built to exacting standards and, if properly installed and maintained, will provide many years of reliable service. The unit must be only be operated in accordance with the EX labeled tag conditions. Consult all local, state, regional, and national agencies regarding specific regulations, requirements, and guidelines. Direct any operation or safety-related questions to your nearest channel partner.

Read and follow every step of these instructions when installing and maintaining the unit.

NOTE: Record the unit model and serial numbers of the machine in the “operating data” form on the inside back cover of this manual. Use this identification on any replacement part orders, or if service or application assistance is required.

02

CONVENTIONS AND DATA PLATE

GRAPHIC CONVENTIONS IN THIS MANUAL

This manual is the result of a risk assessment according to the applicable documents referenced in **Applicable Documentation on page 6**. The following hazard levels are referenced within this manual:

 **DANGER**

Indicates a hazardous situation that, if not avoided, will result in death or serious injury.

 **WARNING**

Indicates a hazardous situation that, if not avoided, could result in death or serious injury.

 **CAUTION**

Indicates a hazardous situation that, if not avoided, could result in minor or moderate injury.

NOTE: Indicates a procedure, practice, or condition that should be followed in order for the equipment to function in the manner intended.

NOTICE

Indicates a situation that can cause damage to the equipment, personal property, and/or the environment or cause the equipment to operate improperly.

NAMEPLATE MARKINGS AND IDENTIFICATION



All machinery designed and certified for use within a hazardous area is marked with a nameplate that differs from that of a standard safe area unit. The label is specific in design and contains, but is not limited to, both the regular information such as manufacturer name and address, serial number, year of manufacture, and product type, but also information such as the explosive area symbol, area classification data governing its suitability for use and location, and also temperature class. The label will have the Conformity European (CE) mark.



Improper use of the machinery beyond or outside the operating details specified on the nameplate or detailed within the manuals, or from that intended within the purchase order or as part of the selection documents, could result in damage or harm to either workers on the plant, the environment, or the operational plant.

All information applied to the machinery such as nameplates, warning labels, arrows for direction, or other warning devices should not be removed from the equipment and should always remain visible.

ATEX Classification Marking Sample

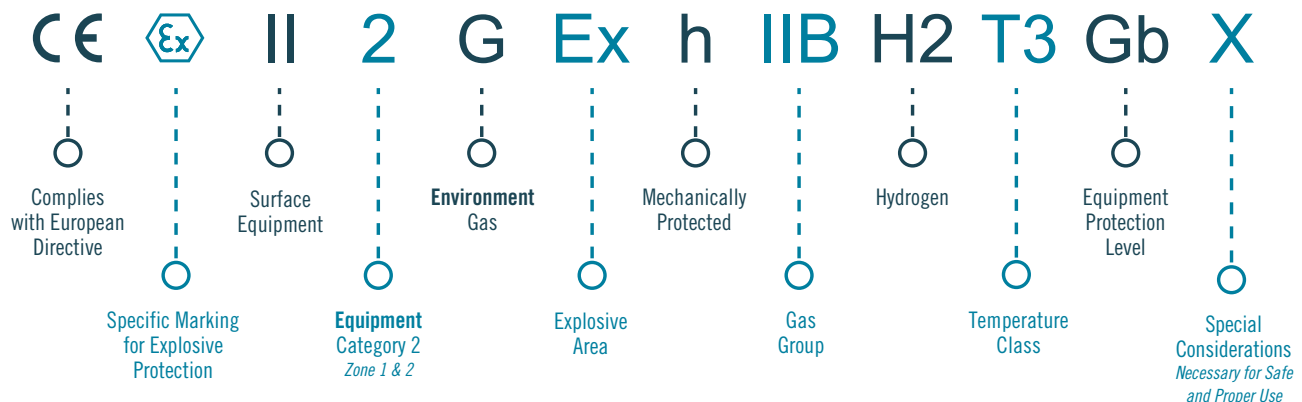

Figure 2-1 – ATEX Classification Marking Sample

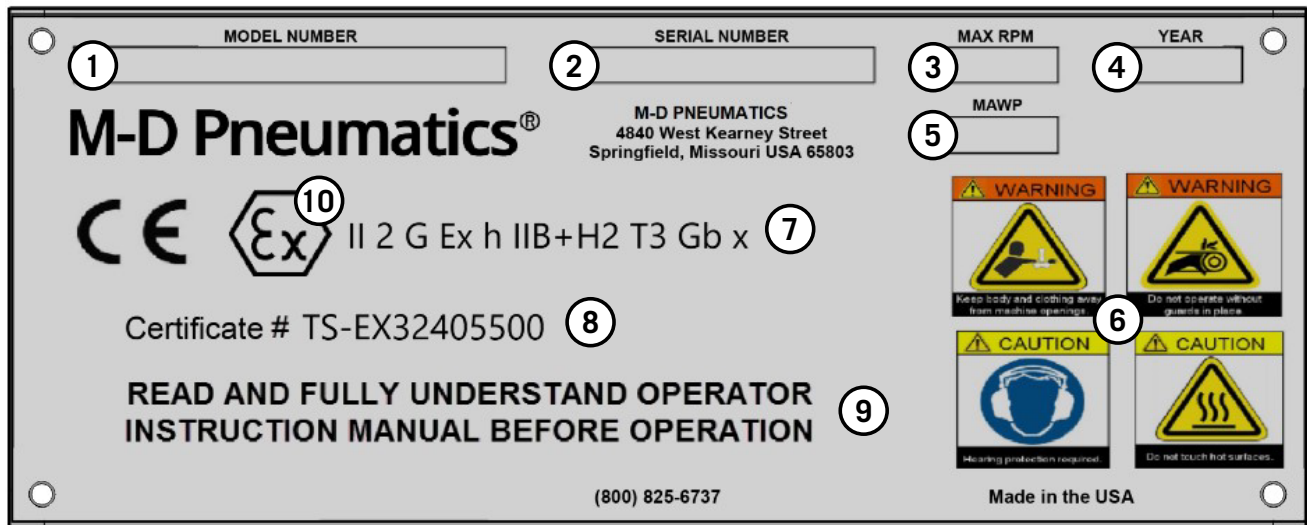

Figure 2-2 – General Operation and Symbols on Data Plate

| GENERAL OPERATION AND SYMBOLS ON DATA PLATE | |
|---------------------------------------------|------------------------------------------------------------------------------------------------------------------|
| 1 | EX Model Number Provides specific configuration details |
| 2 | Serial Number Provides exact manufacturer serial identification number |
| 3 | MAWP Maximum allowable working pressure on blowers. Does not apply to vacuum boosters. |
| 4 | Year Year of manufacture |
| 5 | MAX RPM Maximum rpm can be operated at |
| 6 | Safety Emblems Identification of four safety concerns. <i>See Safety on page 22</i> for complete list. |
| 7 | ATEX External Classification Sample labeling of explosion-proof equipment for device |
| 8 | EX ATEX Certificate # Indicates the specific documentation used with certification |
| 9 | Operator Manual Instruction Requirement for additional user requirements |
| 10 | CE and ATEX Logos Product meets the requirements of the Machinery Directive and the ATEX Directive |

This concerns the surface temperature of external aspects of the equipment.



The external surface temperature is attributed but not limited to the oil temperature, the equipment being properly cooled, and the prevention of frictional heat.

The temperature classes for safe use of the equipment are determined by the following table:

| Temperature Class | Maximum Surface Temperature 32°F (0°C) |
|-------------------|----------------------------------------|
| T1 | 450 |
| T2 | 300 |
| T3 | 200 |
| T4 | 135 |
| T5 | 100 |
| T6 | 85 |



The maximum safe temperature of the equipment must also include the necessary safety margin as required by the ATEX Directive and Standards for the explosive atmosphere in which it is being considered for use.



Operation of the equipment outside the conditions stated within the data sheet and that associated with the order could lead to abnormal temperature increases resulting in consequential risks to the workers, environment, and plant. Such parameters would include but not be limited to inlet pressure, discharge pressure, rotational speed, and the medium being united.



The temperature classes of the units call for them to be operated with an acceptable inlet temperature and the equipment receiving the required cooling medium supply. This information would be included as part of the selection criteria.

The following information is contained on the data plate:

! WARNING

Do not operate without guards in place.

! WARNING

Keep body and clothing away from machine.

During operation, keep body and clothing away from inlet and outlet of the blower.

! CAUTION

Hearing protection is required while the blower is in operation. Noise levels may reach as high as 81 dBA.

! CAUTION

Do not touch hot surfaces.

The temperature limit for EX vacuum boosters and blowers is 350°F (177°C). Do not touch the equipment while it is in operation and ensure it is cool when not in operation.

03

LIFTING

 **WARNING**

Crush Hazard

Be sure to handle the unit using an appropriate device such as a fork truck or appropriate lifting device. See *Table 3-1* for approximate weights. Care should be taken to ensure unit does not overturn during handling and installation.

| | Approx Oil Capacity | | Bare Shaft | C-Flange | Export Box Add |
|---------------|---------------------|-------------------|--------------|------------|----------------|
| | Drive End | Back End | Kg (Lbs) | Kg (Lbs) | Kg (Lbs) |
| EX3204 | 0.35 L (12 oz) | 0.35 L (12 oz) | 55 (120) | 66 (145) | 16 (35) |
| EX3206 | | | 59 (130) | 73 (160) | 18 (40) |
| EX3210 | | | 75 (165) | 88 (195) | 20 (45) |
| EX4009 | 0.71 L (24 oz) | 0.71 L (24 oz) | 91 (200) | 118 (260) | 23 (50) |
| EX4012 | | | 182 (225) | 136 (300) | 25 (55) |
| EX5507 | 1.7 L (57 oz) | 1.7 L (57 oz) | 232 (510) | 245 (540) | 28 (60) |
| EX5511 | | | 273 (600) | 286 (630) | 30 (65) |
| EX5514 | | | 295 (650) | 313 (690) | 32 (70) |
| EX5518 | | | 341 (750) | 359 (790) | 35 (75) |
| EX5524 | | | 436 (960) | 459 (1010) | 37 (80) |

Table 3-1 –Approximate Weights

DESCRIPTION

NOTICE

Refer to specific data sheets for flow capacities and vacuum capacities.

NOTE: Refer to diagrams in this manual for proper rotation and orientation in inlet and discharge port or upstream of the unit inlet port.

Figure 4-1 illustrates the air movement within the machine. In addition, the machine can operate in either direction.

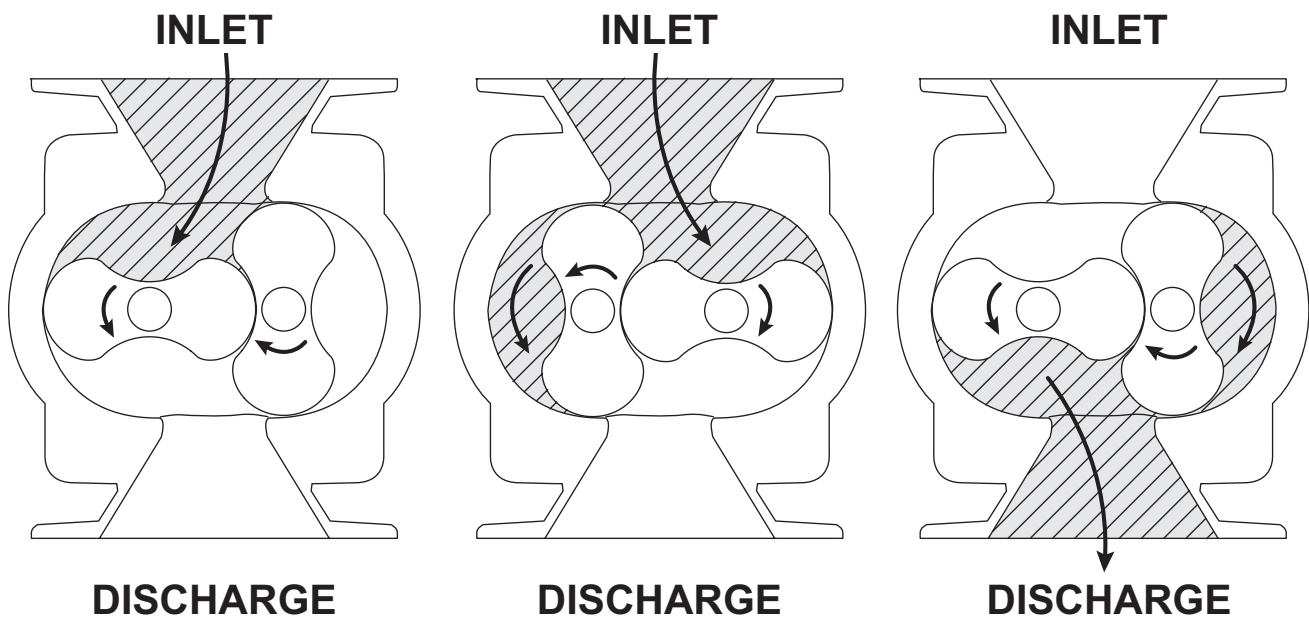

Figure 4-1 – General Operation Principle

Never attempt to control capacity by means of a throttle valve in the intake or discharge piping. This will increase the power load on the drive system, will increase operating temperatures, and ATEX EX3200, EX4000, and EX5500 series rotary lobe units are positive displacement type units whose

uniting capacity is determined by size, operating speed, and differential pressure conditions. Units employ rotors rotating in opposite directions within a housing closed at the ends by end plates.

Description

The inlet to the discharge is sealed with operating clearances that are very small. Internal lubrication is not needed, as there is no moving contact.

Clearances between the rotors during rotation are maintained by a pair of accurately machined helical timing gears, mounted on the two shafts extended outside the air chamber. The inter-meshing rotary lobes are designed to rotate and trap air or gas between each rotor and the housing. As the rotor lobes rotate past the edge of the suction port, the trapped air or gas is essentially at suction pressure and temperature. Since the unit is a constant volume device, the trapped air remains at suction pressure until the leading rotor lobe opens into the discharge port. The close clearances between the rotors inhibit back slippage of the trapped volume from between the rotors, and the trapped volume is forced into the discharge piping. Compression occurs not internal to the unit but by the amount of restriction; either downstream of the unit can overload and/or seriously damage the unit. Likewise, if the possibility exists that flow to the unit inlet may be cut off during normal operation of a process, install an adequate vacuum relief valve. A pressure-type relief valve in the discharge line

near the unit is also recommended for protection against cutoff or blocking in this line. Use check valves on each unit when more than one unit is connected to a discharge line.

Vacuum boosters must be protected by cut-in switches or with bypass valving to limit differential pressure across the booster.

When a belt drive is used, it is possible to adjust unit speed to obtain the desired capacity by changing the diameter of one or both sheaves, or by using a variable-speed motor pulley. In a direct-coupled arrangement, a variable-speed motor or transmission is required.

Gas units can use bypasses, but some applications may require additional cooling. If there is a large volume of high-pressure air or gas downstream of the unit, a check valve in the piping downstream of the unit will protect the unit from over-speeding in a backward direction upon shutdown.

Consult a local distributor or Customer Service if questions arise.

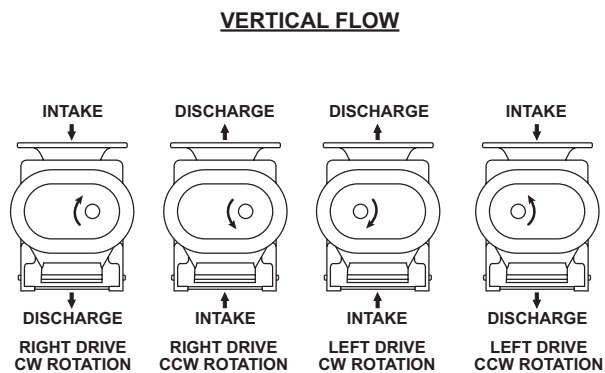

Figure 4-2 – Direction by Rotation

NOTICE

Refer to diagrams in this manual for proper rotation and orientation in inlet and discharge.

**WARNING**

Never exceed the maximum pressure differential. The maximum pressure differential is based on the difference between the inlet pressure and the outlet pressure. Exceeding the maximum pressure differential will cause serious damage to the equipment and could cause bodily injury.

Maximum limits for pressure, temperature, and speed are specified in **Table 4-1 on page 16** for various unit sizes when operated under the standard atmospheric conditions. Do not exceed any of these limits.

NOTICE

Special attention must be paid when a blower has a higher than standard ambient suction temperature. Special recommendations for operating parameters and/or additional cooling may be recommended. Consult the factory or local representative for appropriate information.

To permit continued satisfactory performance, a unit must be operated within certain approved limiting conditions. The manufacturer's warranty is, of course, also contingent on such operation.

Description

Blower Operating Limits (Stand Alone)

| Unit Technical Data | | | | | | | | | | |
|---------------------|--------------|---------------------------|----------------|--------------|------------------------------|--------------|--------------------|------------------------------------------|---------------------------|-------------|
| Unit | GEAR SIZE | MAX DIFFERENTIAL PRESSURE | MAXIMUM VACUUM | MAX/ MIN RPM | MAX ALLOWED WORKING PRESSURE | PORT SIZE | MAX DISCHARGE TEMP | DRIVE SHAFT DIAMETER Standard / C-Flange | ROTOR SHAFT MATERIAL | DRIVE SHAFT |
| | MM (In) | Bar (PSIG) | mbar (in-Hg) | | Bar (PSIG) | DIN (Flange) | C° (F°) | MM (in) | Materials of Construction | |
| 3204 | 82.6(3.25") | 0.689 (10) | 508 (15) | 3600 / 1150 | 2.344 (34) | 50(2") | 177° (350°) | 28 (1.125) 22 (0.875) | Ductile Iron* | Steel* |
| 3206 | 82.6(3.25") | 0.689 (10) | 508 (15) | | 2.344 (34) | 80(3") | | 28 (1.125) 22 (0.875) | | |
| 3210 | 82.6(3.25") | 0.689 (10) | 508 (15) | | 2.344 (34) | 100(4") | | 28 (1.125) 22 (0.875) | | |
| 4009 | 101.6(4") | 0.689 (10) | 508 (15) | 3600 / 1150 | 2.344 (34) | 150 (6") | 177° (350°) | 28 (1.125) 25 (1.0) | Ductile Iron* | Steel* |
| 4012 | 101.6(4") | 0.689 (10) | 508 (15) | | 2.344 (34) | 150 (6") | | 28 (1.125) 25 (1.0) | | |
| 5507 | 139.7 (5.5") | 0.689 (10) | 508 (15) | 3600 / 1150 | 2.344 (34) | 150 (6") | 177° (350°) | 38 (1.5) 32 (1.375) | Ductile Iron* | Steel* |
| 5511 | 139.7 (5.5") | 0.689 (10) | 508 (15) | | 2.344 (34) | 150 (6") | | 38 (1.5) 32 (1.375) | | |
| 5514 | 139.7 (5.5") | 0.689 (10) | 508 (15) | | 2.344 (34) | 150 (6") | | 38 (1.5) 32 (1.375) | | |
| 5518 | 139.7 (5.5") | 0.689 (10) | 508 (15) | | 2.344 (34) | 200 (8") | | 38 (1.5) 32 (1.375) | | |
| 5524 | 139.7 (5.5") | 0.689 (10) | 508 (15) | | 2.344 (34) | 250 (10") | | 38 (1.5) 32 (1.375) | | |

* See VBX Portal for Ductile Iron and Stainless Steel materials of construction

Table 4-1 – Unit Technical Data

Maximum Operating Limits

Maximum discharge temperature is 350°F (177°C).
Maximum temperature is based on a 70°F (21°C) inlet temperature.

 **WARNING**

Never exceed the maximum allowable working pressure (MAWP). The MAWP is based on the absolute pressure of the blower housing and is NOT the maximum allowable pressure differential. Exceeding the MAWP will cause serious damage to the equipment and could cause bodily injury.

INSTALLATION

GENERAL

Definitions:

A **FLAMMABLE gas** by definition is a gas that does NOT have oxygen present sufficient to support combustion.

An **EXPLOSIVE gas** by definition is a gas that DOES have oxygen present sufficient to support combustion.

 **WARNING**

Fire/Explosion Hazard

Do not use the blower in applications that include hazardous and toxic gases.

The blower or booster is intended to internally handle explosive gas mixtures only up to the critical gas combustion pressure of approximately 100 mbar. This pressure varies by gas type. All product selections are required to be evaluated through the VBXpert Portal sizing software prior to quotation. For pressures greater than 100 mbar ATEX Internal classification is not supported.

Definition of Hazardous Gas: A gas that has an NFPA Health Class rating of 4 or a GHS Health rating of 1.

 **WARNING**

Sever Hazard

Be sure to install proper guarding. It is the responsibility of the installer to assure that proper guarding is in place and compliant with all applicable regulatory requirements.

 **WARNING**



Excessive Noise Hazard

Be sure to install inlet and outlet silencers. The bare shaft blower can generate excessive noise. Even with inlet and outlet silencers, hearing protection will be required.

 **WARNING**

Installation/Operation Hazard

Be sure to provide adequate protection, warning, and safety equipment necessary to protect personnel against hazards in the installation and operation of this equipment in the system or facility.

Installation

! WARNING**Unsafe Operation Hazard**

Do not exceed standard MAWP as per Table 4-1. The MAWP must not be exceeded unless specific factory testing of the pressure containing components of the blower has been performed.

! WARNING**Unsafe Operation Hazard**

Do not exceed the maximum operating speed in RPM (rotations per minute) and maximum temperature as stated in 1. The installation of the blower shall take these critical operating parameters into account and adequate control features implemented.

EXAMPLE: Operation of a vacuum booster seldom results in pressure differentials large enough to strain the booster drive train (bearings, gears, and seals). Typically, in vacuum boosting, the maximum allowable temperature limit (the limit is a function of the temperature rise as well as the inlet temperature) for any booster may occur well before the maximum speed or allowable power rating is reached. Temperature rise then becomes the limiting condition. In other words, the operating limit is always to be determined by the maximum rating reached first, and it can be any one of the three: temperature, speed, or horsepower.

NOTICE

Remove the protective covers from the shaft and inspect for damage.

NOTICE

In the event that your unit sustains damage while being shipped to your facility, do not return it to the factory without first obtaining shipping instructions from Customer Service.

Carefully check to ensure that no transit damage has been sustained. If damage has occurred from shipment, file a claim with the carrier immediately. Preserve the shipping container for inspection by the carrier.

Vacuum Gauges and Switches

Deep vacuum requires instrumentation much more sensitive than standard thermometers and mercury-type pressure or vacuum gauges. At operation pressures less than 100 Torr (100 mmHg), use low-deadband cut-in switches and low-mass thermocouples, positioned so the sensor is connected to the inlet and discharge connections of the vacuum booster. NPT connections are provided at each of the inlet and discharge ports for this purpose. Standard temperature switches, because of their higher mass, do not have reaction times fast enough to adequately protect the vacuum booster. Likewise, standard vacuum switches are not recommended for cut-in switches, as vacuum boosting typically requires a very accurate cut-in point. A tachometer will enable periodic checks of operating speed.

Foundation

The blower/booster does not need a special foundation. However, it does require a solid, level floor and adequate frame support. Bolt the unit to the floor and seal any cracks.

Location

Install the unit in a room or outdoor area that supplies adequate space and lighting for routine maintenance. Make sure that indoor installation areas are well ventilated and kept as cool as possible, because operating the unit at elevated

temperatures can result in nuisance overload or temperature shutdowns. An unprotected outdoor installation is satisfactory only when correct lubrication for the expected temperatures is provided. Installer and equipment user is responsible to ensure unit is operated above -26C° (-15F°) to ensure oil viscosity is able to provide lubrication to bearings and seals. **See MD Blower & Booster Lubricants Specifications on page 24**

Mount the unit on a flat, level surface. Use a baseplate that is rigid, solidly supported, and structurally sound. Shim under the legs where necessary so that each leg of the unit supports an equal share of the unit weight. This is necessary to prevent twisting of the unit. Make sure the feet rest evenly on the mounting surface before fastening down. Twisting or cramping the unit during mounting will cause rotor contact and binding during operation, resulting in a condition called “soft foot.”

A unit that is factory-mounted on a base should not require such adjustments. However, since the assembly can become twisted in shipping or installation, check for soft foot after installing the base. Shims may be needed for alignment. Loosen the foot hold-down screws to check foot contact with the mounting surface. Mount the base on a solid foundation or heavy flooring, using shims as necessary at bolting points to prevent warping the assembly.

Transmission of small operating vibrations to a support structure may be objectionable in some applications. Use of vibration isolators or vibration-absorbing materials can be effective in overcoming this transmission. To avoid causing distortion, apply the treatment under the common motor/unit base or mounting plate rather than directly under the feet alone.

PIPING CONNECTIONS

NOTICE

Pipe loading on the blower should be negligible, as pipe loading can cause distortion of the blower. Use proper supports and pipe hangers to assure that there is no loading.

NOTICE

Remove the protective covers from the inlet and outlet ports and inspect for dirt and foreign material.

Make sure piping is accurately squared with the unit and supported independently. Stress imparted from incorrectly aligned piping or mounting will create problems with bearing and seal life, possibly leading to premature internal contact. The unit should sit stress-free and evenly on its supporting surface. Take care to evenly tighten the mounting bolts to avoid imparting undue stress into the unit. Stress can be checked in a free state with feeler stock or verified on a previously installed unit with the aid of a dial indicator. Spring or gap should be less than 0.002 in. (0.05 mm).

Use only clean, new pipe and make certain it is free of scale, cuttings, weld beads, dirt, or any other foreign material. To guard against damage to the unit, make sure that an inlet filter is used. Clean the filter of collected debris after 3 hours of operation and periodically thereafter. **See Piping Connections on page 19** for additional details.

Figure 5-1 shows a typical complete installation of a blower unit and accessories. Note the absence of throttle or shut-off valves in both discharge and intake piping. If it is possible for airflow to be cut off in either line, add a pressure and/or vacuum relief valve. In some installations, it may be desirable to use only an inlet silencer-cleaner supported directly from the unit connection. Keep the weight of accessories and piping to a minimum to prevent unit casing distortion. If the weight exceeds 10% of unit weight, support the components independently of the unit and connect them with a flexible hose or connectors. The approximate weight of the unit is listed in **Table 3-1 on page 12**.

Inlet and outlet connections on all units are large enough to handle maximum volume with minimum friction loss. Maintain same-diameter piping. Do not support silencers by the unit. Avoid stress loads and bending moments.

Be certain all piping is clean internally before connecting to the unit. Place a 16-mesh wire screen backed with hardware cloth at or near the inlet connections for the first 50 hours of use

Installation

until the system is clean. Clean the screen after 3 hours of operation and completely discard it once the system is clean, as it will eventually deteriorate, and small pieces going into the unit can cause serious damage. A horizontal or vertical airflow piping configuration is easily achieved by rearranging the mounting feet position.

Add media filtration as needed to keep foreign/dirty media out of unit. Operation without proper filtration should not be allowed.

It is suggested that installer equip the piping/ system with oxygen sensors to ensure gas is outside of explosive range.

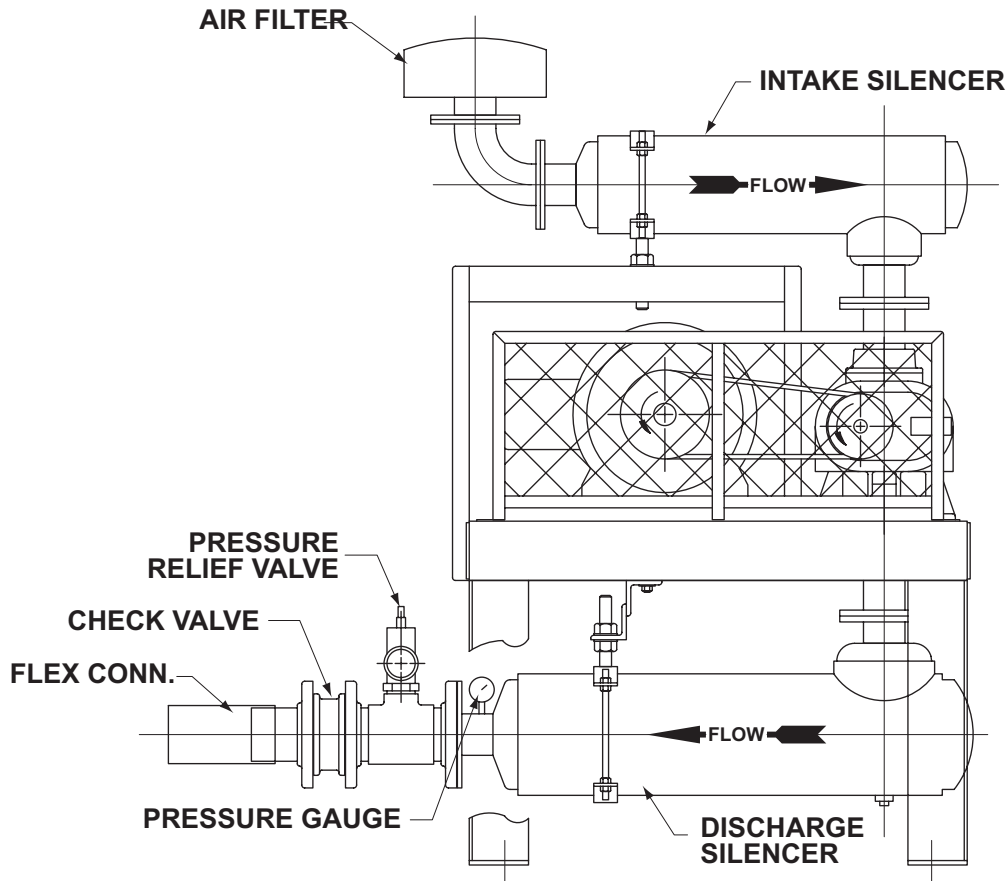

Figure 5-1 – Typical Blower Installation

A blower may be driven by direct coupling to the driver or by V-belt drive for the purpose of obtaining other speeds within the approved range. See **Motor Drives on page 28** for more information.

Blowers are internally and externally treated after factory assembly and testing to protect against rusting in normal atmospheric conditions prior to installation.

The maximum period of internal protection is up to 6 months under average conditions, provided closing plugs and seals are not removed. Protection against chemical or saltwater atmosphere is not provided.

Avoid opening the blower packaging until ready to begin installation, as protection will be quickly lost due to evaporation. For recommended preparations for long-term storage (longer than 6 months), *see Long-Term Storage on page 34.*

Blower Air Intake

To minimize maintenance, supply the blower with the cleanest air possible. The air must not contain any flammable or toxic gases, as the blower will concentrate these gases. This could result in damage to the blower and surrounding property, and could lead to personal injury or death. Do not block or restrict the opening of the blower and/or motor, as they could overheat and fail.

Do not use blowers on explosive or hazardous gases. Do not exceed the limits described in **Table 4-1 on page 16.** Each size blower has limits on performance criteria such as pressure differential, running speed, and discharge temperature.

If it is necessary to take air from a remote source, such as in a vacuum application, make sure the diameter of the piping is at least equal to the diameter of the blower inlet. For distances greater than 20 ft (6 m), enlarge the pipe diameter to reduce inlet restriction. Excessive restriction will reduce the efficiency of the blower and elevate its discharge temperature. The piping used should also be corrosion-resistant and free of scale and dirt. Keep the inlet covered to keep out precipitation, insects, and small animals.

Soft Foot

Soft foot is a condition in which one of the unit feet does not sit flat on the base. Soft foot is usually due to irregularities on the surface to which the unit is mounted. When the bolt on the foot gets tightened, a slight distortion occurs that can affect bearing and seal life as well as internal contact between parts.

ANGULAR SOFT FOOT

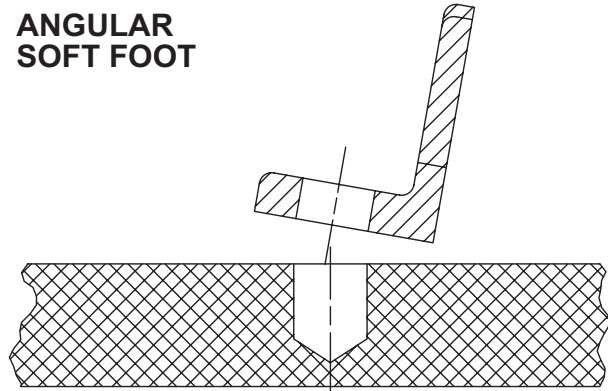

PARALLEL SOFT FOOT

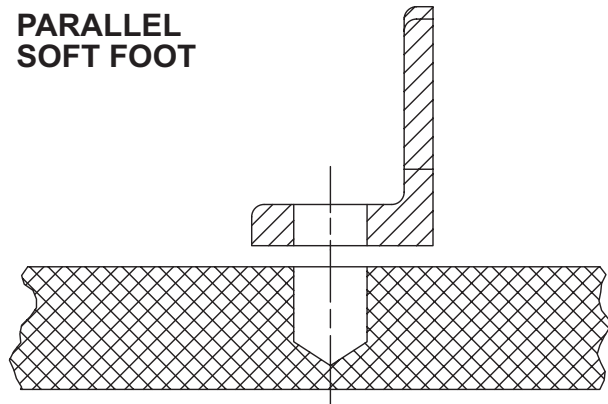

Figure 5-2 – Illustrations of Soft Foot

1. Place the unit on the base.
2. Check each foot for gaps between the foot and base (soft foot). Shim as necessary to fill the gap within 0.002 in. (0.05 mm). **Figure 5-2** shows the two most common types of soft foot conditions. If either type is present at a measurement of more than 0.003 in. (0.076 mm), the unit may fail prematurely.
3. Tighten all bolts.
4. Mount a dial indicator on the base contacting one foot at the 12 o'clock position.
5. Loosen the bolt on that foot. Observe indicator travel and add shims as needed to reduce "spring" to less than 0.002 in. (0.05 mm). Repeat steps 4 and 5 on the remaining feet.

Installation

SAFETY

The use of relief valves is recommended to protect against excessive pressure or vacuum conditions. Test these valves at initial start-up to be sure they are properly adjusted to relieve at or below the maximum pressure differential rating of the unit.

! WARNING**Sever Hazard**

Be sure to install proper guarding. It is the responsibility of the installer to ensure proper guarding is in place and compliant with all applicable regulatory requirements.

**! WARNING****Unsafe Inspection Hazard**

Always apply and follow proper lockout/tag-out procedures. Internal and external rotating parts of the equipment can produce serious physical injuries. The blower should never be run with the inlet or discharge piping removed. If it becomes necessary to inspect the rotating parts or to change V-belts, be absolutely sure that all power to the motor controls has been shut off, the motor controls are locked out, and that they have been properly tagged before proceeding.

**! WARNING****Burn Hazard**

Always allow the equipment to cool to the touch before contacting any component. Blower housing and associated piping or accessories may become hot enough to cause major skin burns on contact.

! WARNING**Electrical Shock Hazard**

Be sure to apply lockout/tag-out procedures to disable the electrical energy source before any service or work is done on the blower.

! WARNING**Personal Injury Hazard**

Be sure to wear adequate ear protection when near operating equipment. Avoid extended exposure in close proximity to machinery with high-intensity noise levels.

NOTICE

Use proper care and good procedures in handling, lifting, installing, operating, and maintaining the equipment.

RECOMMENDED LUBRICANTS FOR BLOWER AND VACUUM BOOSTERS

Positive displacement blowers and vacuum boosters require proper lubrication for bearings, seals and gears to operate effectively and efficiently. Oil is distributed from the oil reservoir to the critical components by means of oil slingers that are attached to the rotor shaft.

M-D Pneumatics only recommends the use of MD full synthetic lubricants in blowers and vacuum boosters. MD lubricants are specifically formulated using unique additives that provide maximum protection and extend the life of your product over mineral oils or semi-synthetic lubricants.

NOTICE

Do not overfill the oil sumps. Overfilling can result in gear damage or oil leaks.

NOTICE

Ensure adequate oil has been added before operating. Units are shipped without oil in the sumps.

A wide range of MD oils are offered that are suitable for operating temperatures based on model, operating speed and discharge temperature of the product.

FOR OXYGEN-ENRICHED SERVICE

Blowers and vacuum boosters operated in oxygen enriched applications should only use non-flammable, PFPE full synthetic lubricants.

Blowers and vacuum boosters used in hydrogen service should only use MD full synthetic oil.

NOTICE

M-D Pneumatics does not accept responsibility for damage caused by use of lubricants that are not manufactured by M-D Pneumatics.

| MD BLOWER & BOOSTER LUBRICANTS SPECIFICATIONS | | | | |
|-----------------------------------------------|------------|-----------|-----------|-----------|
| PRODUCTS | MD ONE | MD PLUS | MD MAX | MD FG |
| VISCOSITY INDEX | 150 | 154 | 157 | 141 |
| @40°C, CST | 99.1 | 231.7 | 340.9 | 99.3 |
| @100°C, CST | 14.4 | 27.6 | 37.2 | 13.9 |
| FLASH POINT °F (°C) | 510 (266) | 480 (249) | 491 (255) | 515 (268) |
| POUR POINT °F (°C) | - 44 (-43) | -49 (-45) | -54 (-48) | -60 (-51) |

NOTE: MD One Vapor Pressure: (mm Hg) 100°F <0.00004; 200°F <0.00018

| MD BLOWER & BOOSTER LUBRICANTS OPTIONS | | | | | |
|----------------------------------------|----------------|----------------|-----------------|------------------|------------------|
| MD OIL TYPE | 1 QUART | 1 GALLON | 5 GALLON | 55 GALLON BARREL | CASE 12 QUARTS |
| MD ONE | 16444-MD1-Q | 16444-MD1-G | 16444-MD1-5G | 16444-MD1-B | 16444-MD1-Q-C |
| MD PLUS | 16444-MD2-Q | 16444-MD2-G | 16444-MD2-5G | 16444-MD2-B | 16444-MD2-Q-C |
| MD MAX | 16444-MD3-Q | 16444-MD3-G | 16444-MD3-5G | 16444-MD3-B | 16444-MD3-Q-C |
| MD FG | 16444-MD1-Q-FG | 16444-MD1-G-FG | 16444-MD1-5G-FG | 16444-MD1-B-FG | 16444-MD1-Q-C-FG |

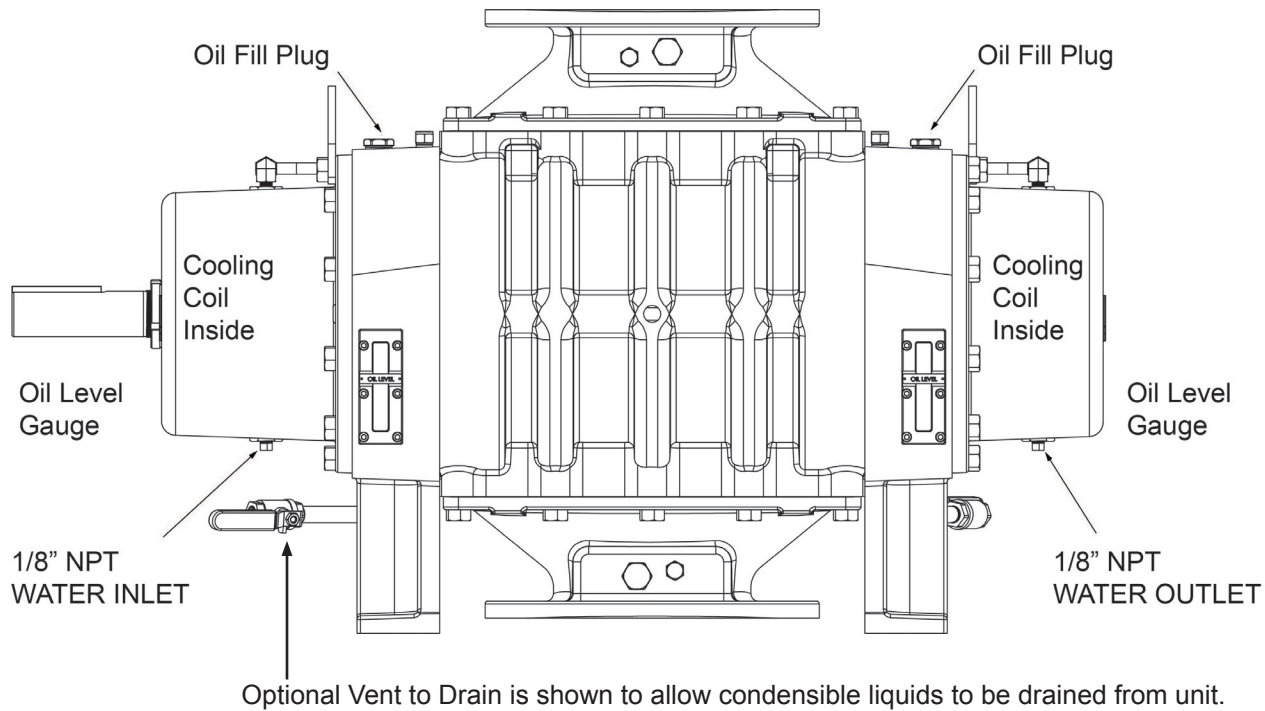

Figure 5-3 – Oil Fill, Drain Connections, and Oil Level Gauges

Frequently Asked Questions Regarding Lubrication

What is the functional detriment if the “wrong oil” is used?

The lubricant is selected based on bearing speed, gear speed, and operating temperature. If the lubricant is too light, it increases wear by not separating the sliding surfaces and it will not remove the heat adequately. If the lubricant is too thick, the drag in the bearings is increased, causing them to run hotter. Thicker lubricant will not flow as readily into the gears and it will reduce the available backlash. Lubricants at our conditions are incompressible.

What is the functional detriment if the oil is not serviced?

If the lubricant is not serviced at the proper interval, the shearing action in the bearings and the gears will begin to take their toll and the lubricant will thicken. The unit will run hotter and the wear

on moving parts will increase. The lubricant will generally appear dirtier, caused by material rubbing off the components. The lubricant will discolor because of overheating. An indicator of the breakdown of a lubricant is the increase in the total acid number (TAN) and a change of 10% in the base viscosity.

Several things are happening as the lubricant goes through the unit. First, it is absorbing frictional energy in the form of heat. This heat has to be dissipated through either surface contact with cooler materials or in a rest volume of lubricant. While reducing the friction, the lubricant is also going through a shearing process and the molecular structure is broken down.

The result is that the lubricant will begin to thicken because of the shorter molecular chains and the dropout of additive packages. The thickened lubricant will cause more drag, increasing the friction and heat and further degrading the lubricant.

Installation

Operation of the blower (environment, run time, speed, and pressure) has a direct effect on duty cycles. The published cycles are based on worst-case conditions.

Hazards Associated with Breakdown or Ignition of Lubrication

 **DANGER**



Asphyxiation Hazard

Be sure to use caution around lubrication media. There is a risk associated with the lubrication media breaking down and resulting in a hazardous fluid or vapor. There may also be a hazard associated with the ignition of the lubrication media. Refer to the lubrication manufacturer's applicable instruction for safety precautions.

Hazards Associated with Hazardous Process Fluids

 **DANGER**



Asphyxiation Hazard

Be sure process gasses are vented properly. It shall be the responsibility of the installer to ensure that piping is adequate, sealing between pipe joints is adequate for the process fluids and proper process and pressure protection devices are in place. It is also the responsibility of the installer to ensure that process gasses are not vented in a manner that would be hazardous.

Refer to the manufacturer of the process media to assure that proper safety precautions are in place.

Blockage or Restriction

NOTICE

Damage to the blower could occur if there is blockage in the inlet or outlet ports or piping. Care should be taken when installing the blower to ensure that there are no foreign objects or restrictions in the ports or piping.

Cooling Coils

NOTICE

If the blower is to be located outdoors or in a building where the temperature surrounding the blower or the water supply and return piping can fall below 35°F (2°C), then care must be taken to ensure that the water (or other cooling liquid) does not freeze and cause damage. Cooling coils must be drained of liquid during downtime unless a recirculating unit using a glycol mixture has been installed.

NOTICE

Units are never shipped from the manufacturer with liquid in the cooling coils.

NOTICE

The cooling water pressure shall not exceed 6.89 bar g (100 psig).

Units are supplied with cooling coils and are identified by the tube that connects the top of the gear (drive) end cover to the bottom of the free (non-drive) end cover. (See **Figure 5-4 on page 27**) for details. M-D Pneumatics recommends water cooling connections for units in applications where the unit operates with discharge temperatures of temperatures of 250°F (120°C) for 4 hours or more per day. Water cooling reduces oil temperature and improves oil viscosity for better lubrication. A water flow of 0.5 – 1.0 GPM (1.9 – 3.8 L/min) is generally sufficient to maintain oil temperatures of 150°F (65°C) or below. Do not allow water pressure to exceed 100 psig (6.89 bar g).

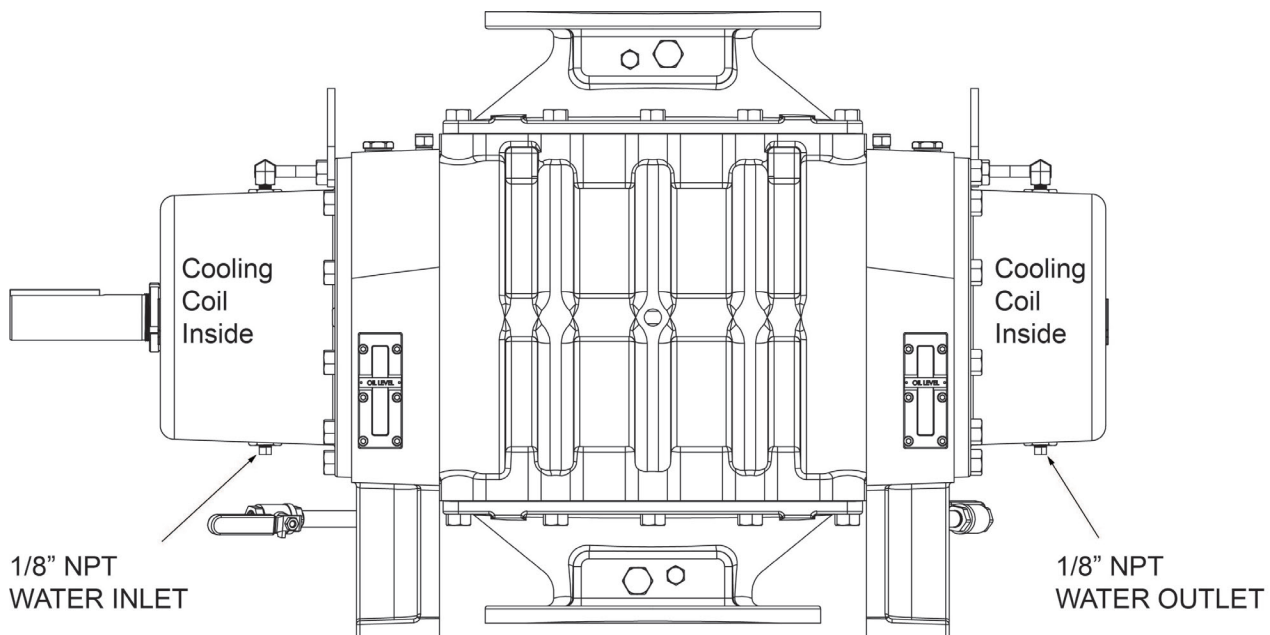

Figure 5-4 – Water Cooling Connections

MOTOR DRIVES

Two drive connections commonly used are direct-coupled and the V-belt drive.

Direct-Coupled Drive

When installing the motor directly to the unit, align the shafts to the coupling according to the coupling manufacturer's instructions.

Coupling halves must correctly fit the unit and drive shafts so that only light tapping is required to install each half. The two shafts must be accurately aligned. A direct-coupled unit and motor must be aligned with the two shafts having no more than 0.005 in. (13 mm) total indicator reading (TIR). Make sure the face is aligned within 0.002 in. (0.05 mm).

Establish proper gap between coupling halves according to the coupling manufacturer's instructions with the motor armature. Proper gap will minimize the chance for end thrust on the unit shaft. Re-align and grease all direct-coupled base-mounted units after field installation.

V-Belts

If the motor and unit are V-belt connected, the sheaves on both the motor and unit shafts should be as close to the shaft bearings as possible. Unit sheave is not more than 1/4 in. (6.5 mm) from the unit drive end cover. The drive sheave is as close to the driver bearing as possible. Take care when installing sheaves on the unit and motor shafts. Make sure the face is accurately in line to minimize belt wear.

Adjust the belt tension to the manufacturer's specifications using a belt tension tester. Check new belts for proper tension after 24 hours of run time. When manufacturer data is not available, industry guidelines recommend 1/64 in. deflection for each inch of span (0.157 mm deflection per centimeter of span) at 8 – 10 lb (3.6 – 4.5 kg) of force in the center of the belt.

Insufficient tensioning is often indicated by slipping (squealing) at start-up. Do not use belt dressing on V-belts. Keep sheaves and V-belts free of oil and grease. Remove tension from belts if the drive is to be inactive for a period of 30 days or more. For more specific information, consult the drive manufacturer. In a V-belt drive, the unit sheave must fit its shaft accurately, run true, and be mounted as close to the bearing housing as possible to minimize bearing loads.

A tight or driving fit will force the drive shaft out of its normal position and cause internal damage. A loose fit will result in shaft damage or breaking. Make sure the motor sheave fits correctly and is properly aligned with the unit sheave.

NOTICE

Anti-static type drive belts or couplings are recommended and should be in constant contact with grounded metal sheaves or in contact with grounding brush to prevent buildup of static charge. Use anti-static belts or couplings for the appropriate area classification.

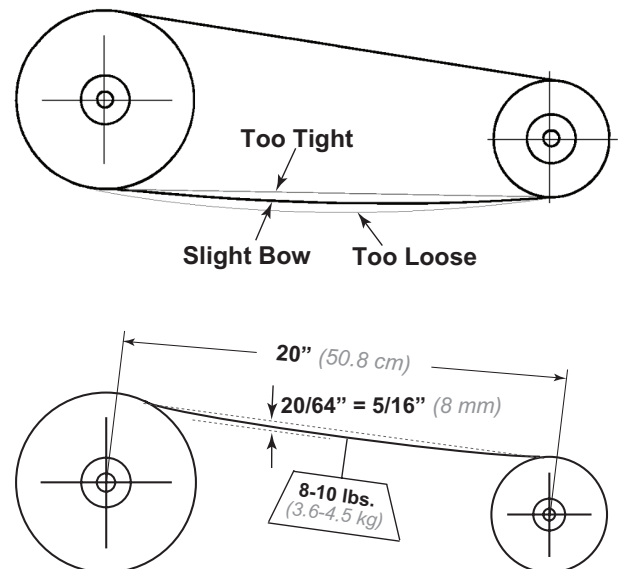

Figure 5-5 – Setting of proper tension for a V-belt drive

Check the unit after installation and before applying power by rotating the drive shaft by hand.

If the drive shaft does not rotate freely:

- Look for uneven mounting, piping strain, excessive belt tension, or coupling misalignment
- Check the unit to make sure oil was added to the reservoirs

Motor and Electrical Connections By Others

NOTICE

The motor and connections shall be protected to ensure that product and environmental condensation does not come into contact with the electrical connections.

NOTICE

It is the responsibility of the installer to ensure that the EX type motor is in compliance with the latest edition of IEC 60204-1 and all electrical connections are performed per IEC 60204-1. This includes overcurrent protection.

1. Wire the motor and other electrical devices, such as the solenoid valves and temperature switch, to the proper voltage and amperage as indicated on the nameplate of the component being wired.
2. Turn the unit by hand after wiring is completed to determine that there are no obstructions and that the unit turns freely. Then, momentarily start the unit to check the direction of rotation. **See Figure 4-2 on page 14** shows direction of airflow in relation to rotor rotation.
3. The airflow direction can be altered by reversing the appropriate motor leads.

NOTICE

Ensure that the product has been properly grounded. An ohm meter may be used to verify resistance that is acceptable in accordance with regional electrical codes.

06

OPERATION

GENERAL

Definitions:

A **FLAMMABLE gas** by definition is a gas that does NOT have oxygen present sufficient to support combustion.

An **EXPLOSIVE gas** by definition is a gas that DOES have oxygen present sufficient to support combustion.

WARNING

Fire/Explosion Hazard

Do not use the blower in applications that include hazardous and toxic gases.

The blower or booster is intended to internally handle explosive gas mixtures only up to the critical gas combustion pressure of approximately 100 mbar. This pressure varies by gas type. All product selections are required to be evaluated through the VBXpert Portal sizing software prior to quotation. For pressures greater than 100 mbar ATEX Internal classification is not supported.

Definition of Hazardous Gas: A gas that has an NFPA Health Class rating of 4 or a GHS Health rating of 1.

WARNING



Do not operate without guards in place.



WARNING

Unsafe Operation Hazard

Do not exceed the maximum operating speed in RPM (rotations per minute), the maximum pressure differential, maximum vacuum, and maximum temperature rise as stated in *Table 1-2 on page 6*.

BLOWER

Before starting the unit for the first time under power, recheck the installation thoroughly to reduce the likelihood of difficulties. Use the following checklist as a guide, but also consider any other special conditions in your installation.

1. Be certain no bolts, rags, or dirt have been left in the unit.

2. Be certain that inlet piping is free of debris. If an open outdoor air intake is used, be sure the opening is clean and protected by an inlet filter. This also applies to indoor use.
3. If installation is not recent, check unit leveling, drive alignment, belt tension, and tightness of all mounting bolts.
4. Be certain the proper volume of oil is in the oil reservoir chambers.
5. Be certain the driving motor is properly lubricated and connected through suitable electrical overload devices.
6. With electrical power off and locked out to prevent accidental starting, rotate the unit shaft several times by hand to make sure the unit is rotating freely. Unevenness or tight spots are indicators of a condition that should be corrected before progressing.
7. Check motor rotation by momentarily energizing the motor and then checking the flow direction of the unit. Reverse the motor connections if the flow is in the wrong direction.

8. Carry out initial operation under “no load” conditions by opening all valves and venting the discharge to the atmosphere, if possible. Then, start the motor briefly, listen for unusual noises, and make sure the unit coasts freely to a stop.
9. If no problem appears, repeat this check and let the motor run slightly longer. If any questions exist, investigate before proceeding.

Assuming all tests are satisfactory, the unit will now be ready for continuous full-load operation. During the first several days, check periodically to make sure all conditions remain acceptable and steady. These checks may be particularly important if the unit is part of a process system where conditions may vary. At the first opportunity, stop the unit and clean or remove the inlet filter. Also recheck leveling, coupling alignment or belt tension, and mounting bolts for tightness.

START-UP CHECKLIST

It is recommended that these start-up procedures be followed in sequence and checked off () in the boxes provided in any of the following cases.

| | | | |
|----------------------------------------------------------------------------------------------------------------------|--------------------------------------------------------------------------------------------------------------------------------------------------------------------------------------------------------|------------------------------------------------------------------------------------------------------------------------------------------------------|----------------------|
| <ul style="list-style-type: none"> • During initial installation • After any shutdown period | | <ul style="list-style-type: none"> • After maintenance work has been performed • After unit has been moved to a new location | |
| DATES CHECKED: | <input type="text"/> | <input type="text"/> | <input type="text"/> |
| <input type="checkbox"/> <input type="checkbox"/> <input type="checkbox"/> <input type="checkbox"/> | Check the unit for proper lubrication. Proper oil level is critical. See MD Blower & Booster Lubricants Specifications on page 24 for information on acceptable lubricants for the product. | | |
| <input type="checkbox"/> <input type="checkbox"/> <input type="checkbox"/> <input type="checkbox"/> | Check the V-belt drive for proper belt alignment and tension. | | |
| <input type="checkbox"/> <input type="checkbox"/> <input type="checkbox"/> <input type="checkbox"/> | Carefully turn the rotors by hand to be certain they do not bind. | | |

Operation

⚠ WARNING**Sever Hazard**

Be sure to disconnect power and apply lockout/tag-out procedures before touching any rotating element of the blower, motor, or drive components.

| | |
|-----------------------------------------------------------------------------------------------------|-------------------------------------------------------------------------------------------------------------------------------------------------------------------------------------|
| <input type="checkbox"/> <input type="checkbox"/> <input type="checkbox"/> <input type="checkbox"/> | "Bump" the unit with the motor to check rotation and to be certain it turns freely and smoothly. |
| <input type="checkbox"/> <input type="checkbox"/> <input type="checkbox"/> <input type="checkbox"/> | Start the unit and operate it for 30 minutes at no load. During this time, feel the cylinder for hot spots. If minor hot spots occur, see <i>Troubleshooting on page 39.</i> |
| <input type="checkbox"/> <input type="checkbox"/> <input type="checkbox"/> <input type="checkbox"/> | Apply the load and observe the operation of the unit for 1 hour. |
| <input type="checkbox"/> <input type="checkbox"/> <input type="checkbox"/> <input type="checkbox"/> | If minor malfunctions occur, discontinue operation and see <i>Troubleshooting on page 39.</i> |

Prior to the start-up of the equipment that is intended for use in a hazardous area, it is necessary to conduct some fundamental checks. First, it is necessary to confirm that the equipment markings meet or exceed that which is designated for the area. It is then necessary that the ancillary equipment fitted to the unit also meets or exceeds the area classification.

STARTING A VACUUM BOOSTER

1. Check the oil for proper level at both ends of the booster.
2. Add or drain oil as necessary to bring the oil to the correct level. **See *Figure 5-3 on page 25.***
3. Start the backing unit.
4. When pressure is reduced sufficiently, start the booster unit. A pressure switch should be installed to start the booster at a predetermined pressure. The booster is water-cooled, so turn on the cooling water when the booster is started. Adjust the water flow so that the discharge water temperature is no more than lukewarm (70° – 80°F [21° – 26°C]).

OPERATING

The upper temperature limit for the unit is 350°F (177°C) measured in the exhaust gas stream with a low-mass thermocouple. When this temperature limit switch is installed, as the temperature exceeds the predetermined temperature, the unit motor will stop and cannot be restarted until the temperature drops below the trip setting of the temperature switch.

NOTICE

Use of a thermowell insulates the thermocouple. Invalid and delayed readings will result. This can result in ineffective protection devices.

NOTICE

The upper temperature limits are not intended for continuous operation. Consult with factory for detailed information assistance.

NOTICE

If rated vacuum or pressure levels are exceeded, process fluids will migrate to other parts of the blower and system.

WARNING**Exposure Hazard**

Be sure all connections are protected from human contact. Physical harm may occur if body parts are in contact or exposed to the process vacuum.

WARNING**Fire/Explosion Hazard**

Do not use the blower in applications that include hazardous and toxic gases.

The blower or booster is intended to internally handle explosive gas mixtures only up to the critical gas combustion pressure of approximately 100 mbar. This pressure varies by gas type. All product selections are required to be evaluated through the VBXpert Portal sizing software prior to quotation. For pressures greater than 100 mbar ATEX Internal classification is not supported.

Definition of Hazardous Gas: A gas that has an NFPA Health Class rating of 4 or a GHS Health rating of 1.

NOTICE

Do not stop the blower if there are high outlet pressures in the outlet piping. Unload the outlet piping prior to shutting down the blower.

2. Isolate the unit from the vacuum system and vent the unit to the atmosphere.
3. Turn off the cooling water.
4. Stop the backing unit.
5. See the component instruction manual for details.

RECOMMENDED SHUTDOWN PROCEDURE TO MINIMIZE RISK OF FREEZING OR CORROSION

When an air piping system has high humidity or moisture, water condensation can occur after the unit is shut down and it begins to cool. Condensation creates an environment favorable to corrosion of the iron internal surfaces and causes ice formation in cold weather. Both conditions can close the operating clearances, causing the unit to fail upon future start-up.

The following shutdown procedure minimizes the risk of moisture condensation, corrosion, and freezing.

1. Isolate the unit from the moist system piping, allowing the unit to intake atmospheric air. Operate the unit under a slight load, allowing the unit to heat within safe limits. The heat generated by the unit will quickly evaporate residual moisture.
2. For extended shutdown, inject a small amount of a light lubricating oil such as 3-in-One® or a spray lubricant such as WD-40® into the inlet of the unit just before shutdown. The lubricant will provide an excellent protective coating on the internal surfaces. If using a spray lubricant, take care to prevent the applicator tube from getting sucked into the unit. The applicator tube will damage the unit, likely to a degree where repair would be required.

1. Stop the unit by turning off the motor.

LONG-TERM STORAGE

Anytime the unit will be stored for an extended period of time, make sure it is protected from corrosion by following this procedure:

1. Spray the interior (lobes, housing, and end plates) with rust preventative. Repeat as conditions dictate and on an at least a yearly basis.
2. Fill both end covers completely full of oil.
3. Firmly attach a prominent tag stating that the end covers are full of oil and must be drained and refilled to proper levels before start-up.
4. Apply a rust-preventative grease to the drive shaft.
5. Spray all exposed surfaces, including the inlet and discharge flanges, with rust preventative.
6. Seal the inlet, discharge, and vent openings. It is not recommended that the unit be set in place, piped to the system, and allowed to remain idle for a prolonged amount of time. If any component is left open to the atmosphere, the rust preventative will escape and lose its effectiveness.
7. During storage, make sure the unit does not experience excessive vibration.
8. Attach a desiccant bag to one of the covers to prevent condensation from occurring inside the unit. Make sure any desiccant bag (or bags) is attached to the covers so that they will be removed before start-up of the unit.
9. Store the unit in an air-conditioned and heated building if possible. If air-conditioned and heated storage is not possible, make conditions as dry as possible.
10. If possible, rotate the drive shaft by hand at least monthly to prevent seals from setting in one position.

MAINTENANCE

GENERAL

Regular inspection of the unit and its installation, along with complete checks on operating conditions, will pay dividends in added life and usefulness. Also, service the drive per the manufacturer's instructions and lubricate the coupling or check the belt drive tension. Use thermometers and gauges to make sure that unit operating temperature and pressure remain within allowed limits.

 **WARNING****Exposure Hazard**

Be sure the pump and parts are free of hazardous media prior to servicing. The blower and parts may contain hazardous media.

 **WARNING****Electric Shock Hazard**

Be sure to isolate and de-energize the electrical service prior to maintenance. Apply appropriate procedures to assure electrical supply is de-energized and cannot be inadvertently energized during maintenance.

 **WARNING****Exposure Hazard**

Be sure piping and product is isolated prior to maintenance of blower. Apply appropriate procedures to assure piping and product is isolated and that inadvertent opening of valves cannot occur during maintenance.

 **WARNING****Sever Hazard**

Be sure the guards are in place and secured when performing inspection during routine maintenance.

Pay special attention to lubrication of timing gears and bearings according to the information in *Recommended Lubricants for Blower and Vacuum Boosters on page 23*.

When a unit is taken out of service, it may require internal protection against rusting or corrosion. The need for such protection must be a matter of judgment based on existing conditions as well as length of downtime. Protect the unit immediately under atmospheric conditions producing rapid corrosion. *See Long-Term Storage on page 34*.

REGULAR MAINTENANCE

A well-designed maintenance program will add years of service to the unit.

Maintenance

Check a newly installed unit frequently during the first month of operation, especially lubrication. With the unit at rest, check the oil level in both the gear (drive) end and free (non-drive) end of the unit and add oil as needed. Complete oil changes are recommended based on a regular oil sampling

program depending on the type of conditions of service, brand of oil, and operating temperature. The sampling program will determine if changes are required more frequently if excessive operating temperatures are encountered. The following is recommended as a minimum maintenance program.

| DAILY | WEEKLY | MONTHLY | MISCELLANEOUS |
|--------------------------------------------------------------------------------------------------------------------------------------------------------------------------------------------------------|-------------------------------------------------------------------------------------------------------------------------------------------------------------------------------------------------------------------------------------------------------------------|--------------------------------------------------------------------------------------------------------------------------------------------------------------------------------------------------------------------------------|-------------------------------------------------------------------------------------------------------------------------------------------------------------------------------------------------------------------------------------------------------------------------------------------------------------------------------------------------------------------------------------------------------------------------------------------------------------------------------------------------------------------------------------------------------------------------------------------------------------------------------------------|
| <ol style="list-style-type: none"> 1. Check and maintain oil level, and add oil as necessary. 2. Check for unusual noise or vibration (See Troubleshooting on page 39). | <ol style="list-style-type: none"> 1. Clean all air filters. A clogged air filter can seriously affect the efficiency of the blower and cause overheating and oil usage. 2. Check the relief valve to make sure it is operating properly. | <ol style="list-style-type: none"> 1. Inspect the entire system for leaks. 2. Inspect the condition of the oil and change if necessary. 3. Check drive belt tension and tighten if necessary. | <ol style="list-style-type: none"> 1. Bearings should be considered in view of the drive arrangement to ensure that they are not overloaded. The bearings should be changed every 25,000 hours or 3 years, whichever occurs first. Vibration mounting holes are included for every ATEX unit. The installation of vibration monitoring equipment will provide data that may indicate early bearing failure. 2. Seals should be replaced as a set and typically every 8,500 hrs subject to use and medium being pumped. They should also be changed if a leak is suspected or should a bearing fail. |

NOTICE

Oil levels should be checked every 24 hours of operation.

Proper oil drain schedules require oil be changed before the contaminant load becomes so great that the lubricating function of the oil is impaired or heavy disposition of suspended contaminants occurs. To check the condition of the oil, drain a sample into a clean container and check for the presence of water or solids. Slight discoloration of the oil should not necessitate an oil change.

SPARE PARTS - Only Sold to Authorized Service Centers

Should adjustments or replacement be needed, repairs must be performed locally via an Authorized Service Center (ASC).

The ASC will provide complete disassembly and assembly using genuine EX ATEX replacement parts, assembly drawings, and repair kits that are available for all models. These kits contain all the seals, bearings, O-rings, locks, and special retaining screws necessary for an overhaul.

FACTORY SERVICE AND REPAIR

With proper care, EX ATEX units will give years of reliable service. The parts are machined to close tolerances and require special tools by mechanics who are skilled at this work. Should major repairs become necessary, contact the factory for the location of the nearest ASC facility.

NOTICE

Current regulations require Material Safety Data Sheets to be completed and forwarded to ASC on any unit being returned for any reason that involves handling of or involvement with hazardous gases or materials. This is for the protection of the employees of ASC who are required to perform service on this equipment. Failure to do so will result in service delays.

Maintenance

NOTICE

Be sure to monitor the bearings for vibration. Performing an oil sampling procedure is highly recommended.

With regards to ATEX EX Blowers and Boosters, it is important to understand the correct and proper replacement of items such as bearings. This is to prevent equipment failure during use and to avoid operating the equipment outside that which is expected and considered safe.

Switch maintenance should be performed at the switch manufacturer's recommended maintenance interval or the end users recommended maintenance interval, whichever is shorter. Repair or replace if the switch is found not to be in proper working order.

WARNING

Electrostatic Spark Hazard

Do not use materials, especially non-metallic types or other materials, that may cause an electrostatic spark when cleaning dust externally.

Care should be taken to ensure that the equipment is not be subjected to dusty environments. It is also important that appropriate action is taken to ensure that the unit is kept free from dust internally and that filters and traps are used. The filter elements of the associated equipment must also be kept in good working order and replaced on a routine basis to ensure that they do not create unexpected conditions that may hinder the unit's performance or compromise its safety. In the event that foreign bodies enter the unit, care should be taken to ensure that they are removed, and the unit is free from obstruction or contamination.

 **WARNING**
Unsafe Operation Hazard

Be sure the equipment is checked periodically and that a service history is kept showing that the equipment is being maintained in accordance with recommendations. Failure to upkeep the maintenance schedules could compromise the safe operation of the equipment.

The units must be maintained by trained, approved personnel at an ASC. All spare/replacement parts must also be of the M-D Pneumatics original EX ATEX parts supply, which can only be installed by an ASC.

RESPONSIBILITIES AND WARRANTY

In the event that the equipment is operated outside the known conditions or is not maintained in accordance with content detailed within the associated published owner's and/or operators' manuals, then M-D Pneumatics reserves the right to deny warranty.

M-D Pneumatics also maintains this viewpoint in the event that non-original parts are used or should either a non-competent or unapproved personnel assemble the unit incorrectly.

Excludes warranty or responsibilities in the event of the equipment being used outside the agreed conditions stated within the supporting documentation of the order or that determined by its markings should any damage to persons, equipment, or the environment be caused.

The conditions of the warranty also exclude the responsibilities of damage caused to other related equipment for whatever reason.

Refer to the standard Terms & Conditions of Sale for a complete clarification of all other terms under this warranty.

In the event that further clarification is required or if there are any uncertainties about any aspects related to those within this manual or the associated one, then it is deemed necessary that the competent persons must be consulted at the factory to avoid potential failures or potentially explosive conditions.

It is also necessary to follow the M-D Pneumatics warranty policy in the event of a potential claim. All the conditions detailed within it must be adhered to.

NOTICE

When returning a blower to the factory for repair under warranty, please note the factory will not accept any unit that arrives without authorization. Contact Customer Service for return authorization.

TROUBLESHOOTING

Although M-D Pneumatics units are well designed and manufactured, problems may occur due to normal wear and the need for readjustment. The following chart lists symptoms that may occur along with probable causes and remedies. All repairs must be made by an Authorized Service Center (ASC) location.

| SYMPTOM | PROBABLE CAUSE | REMEDIES |
|--------------------------------|-----------------------------------------------------|----------------------------------------------------------------------------------------------------------------|
| Loss of oil | Gear housing not tightened properly | Tighten gear housing bolts. |
| | Lip seal failure | Disassemble and replace lip seal. (ASC only) |
| | Insufficient sealant | Remove gear housing and replace sealant. (ASC only) |
| | Loose drain plug | Tighten drain plug. |
| Excessive bearing or gear wear | Improper lubrication | Correct oil level. Replace dirty oil. See MD Blower & Booster Lubricants Specifications on page 24. |
| | Excessive belt tension | Check belt manufacturer's specifications for tension and adjust accordingly. |
| | Coupling misalignment | Check carefully. Re-align if necessary. |
| Lack of volume | Slipping belts | Check belt manufacturer's specifications for tension and adjust accordingly. |
| | Worn lobe clearances | Check for proper clearances via an Authorized Service Center (ASC). |
| | Speed too low | Increase unit speed within limits. |
| | Obstruction in piping | Check system to ensure an open flow path. |
| Knocking | Unit out of time | Re-time via an ASC. |
| | Distortion due to improper mounting or pipe strains | Check mounting alignment and relieve pipe strains. |
| | Excessive pressure differential | Reduce to manufacturer's recommended pressure. Examine relief valve and reset if necessary. |
| | Worn gears | Replace timing gears via an ASC. |

Troubleshooting

| SYMPTOM | PROBABLE CAUSE | REMEDIES |
|----------------------------|----------------------------------------------|-----------------------------------------------------------------------------------------------|
| Excessive unit temperature | Too much or too little oil in gear reservoir | Check oil level. See Recommended Lubricants for Blower and Vacuum Boosters on page 23. |
| | Too low operating speed | Increase unit speed within limits. |
| | Clogged filter or silencer | Remove cause of obstruction. |
| | Excessive pressure differential | Reduce pressure differential across the unit. |
| | Elevated inlet temperature | Reduce inlet temperature. |
| | Worn lobe clearances | Check for proper clearances via an ASC. |
| Rotor end or tip drag | Insufficient assembled clearances | Correct clearances via an ASC. |
| | Case or frame distortion | Check mounting and pipe strain. |
| | Excessive operating pressure | Reduce pressure differential. |
| | Excessive operating temperature | Reduce pressure differential or reduce inlet temperature. |
| Vibration | Belt or coupling misalignment | Check carefully. Re-align if necessary. |
| | Lobes rubbing | Check cylinder for hot spots, and then check for lobe contact at these points via an ASC. |
| | Worn bearings or gears | Check condition of gears and bearings via an ASC. |
| | Unbalanced or rubbing lobes | Possible buildup on casing or lobes, or inside lobes. Remove buildup and restore clearances. |
| | Driver or unit loose | Check mounting and tighten if necessary. |
| | Piping resonance | Check pipe supports, check resonance of nearby equipment, and check foundation. |

ASSEMBLY CLEARANCES

| MODEL | LOBES TO END PLATES | | LOBE TO HOUSING |
|--------|---------------------------------------|---------------------------------------|---------------------------------------|
| | GEAR END | FREE END | TIP-PORT |
| EX3204 | .003-.007 in. (.08- .18 mm) | .006-.011 in. (.15- .28 mm) | .006-.010 in. (.15- .25 mm) |
| EX3206 | .003-.007 in. (.08- .18 mm) | .008-.013 in. (.20- .33 mm) | .006-.010 in. (.15- .25 mm) |
| EX3210 | .003-.007 in. (.08- .18 mm) | .016-.021 in. (.41- .53 mm) | .006-.010 in. (.15- .25 mm) |
| EX4009 | .004-.007 in. (.10- .18 mm) | .010-.015 in. (.25- .38 mm) | .006-.011 in. (.15- .28 mm) |
| EX4012 | .004-.007 in. (.10- .18 mm) | .016-.021 in. (.41- .53 mm) | .006-.011 in. (.15- .28 mm) |
| EX5507 | 0.005 – 0.007 in. (0.13 – 0.18 mm) | 0.009 – 0.013 in. (0.23 – 0.33 mm) | 0.012 – 0.014 in. (0.30 – 0.36 mm) |
| EX5511 | 0.005 – 0.007 in. (0.13 – 0.18 mm) | 0.012 – 0.016 in. (0.30 – 0.41 mm) | 0.012 – 0.014 in. (0.30 – 0.36 mm) |
| EX5514 | 0.005 – 0.007 in. (0.13 – 0.18 mm) | 0.014 – 0.018 in. (0.36 – 0.46 mm) | 0.012 – 0.014 in. (0.30 – 0.36 mm) |
| EX5518 | 0.005 – 0.007 in. (0.13 – 0.18 mm) | 0.018 – 0.023 in. (0.46 – 0.58 mm) | 0.012 – 0.014 in. (0.30 – 0.36 mm) |
| EX5524 | 0.004 – 0.007 in. (0.10 – 0.18 mm) | 0.025 – 0.030 in. (0.64 – 0.76 mm) | 0.012 – 0.017 in. (0.30 – 0.43 mm) |

10

TORQUE CHART

Data shown represents “wet” torque values.

| PART DESCRIPTION | TORQUE |
|---------------------------|------------------------|
| CAP SCREW 10-32UNF | 3 ft-lb (4 N-m) |
| CAP SCREW 1/4"-20UNC GR5 | 6 ft-lb (8 N-m) |
| CAP SCREW 5/16"-18UNC GR5 | 13 ft-lb (17 N-m) |
| CAP SCREW 3/8"-16UNC GR5 | 23 ft-lb (31 N-m) |
| CAP SCREW 1/2"-13UNC GR5 | 57 ft-lb (77 N-m) |
| CAP SCREW 5/8"-14UNC GR5 | 113 ft-lb (153 N-m) |
| CAP SCREW 3/4"-10UNC GR5 | 200 ft-lb (271 N-m) |

PARTS LIST AND ASSEMBLY DRAWINGS

Model EX3200 - Double Envelope

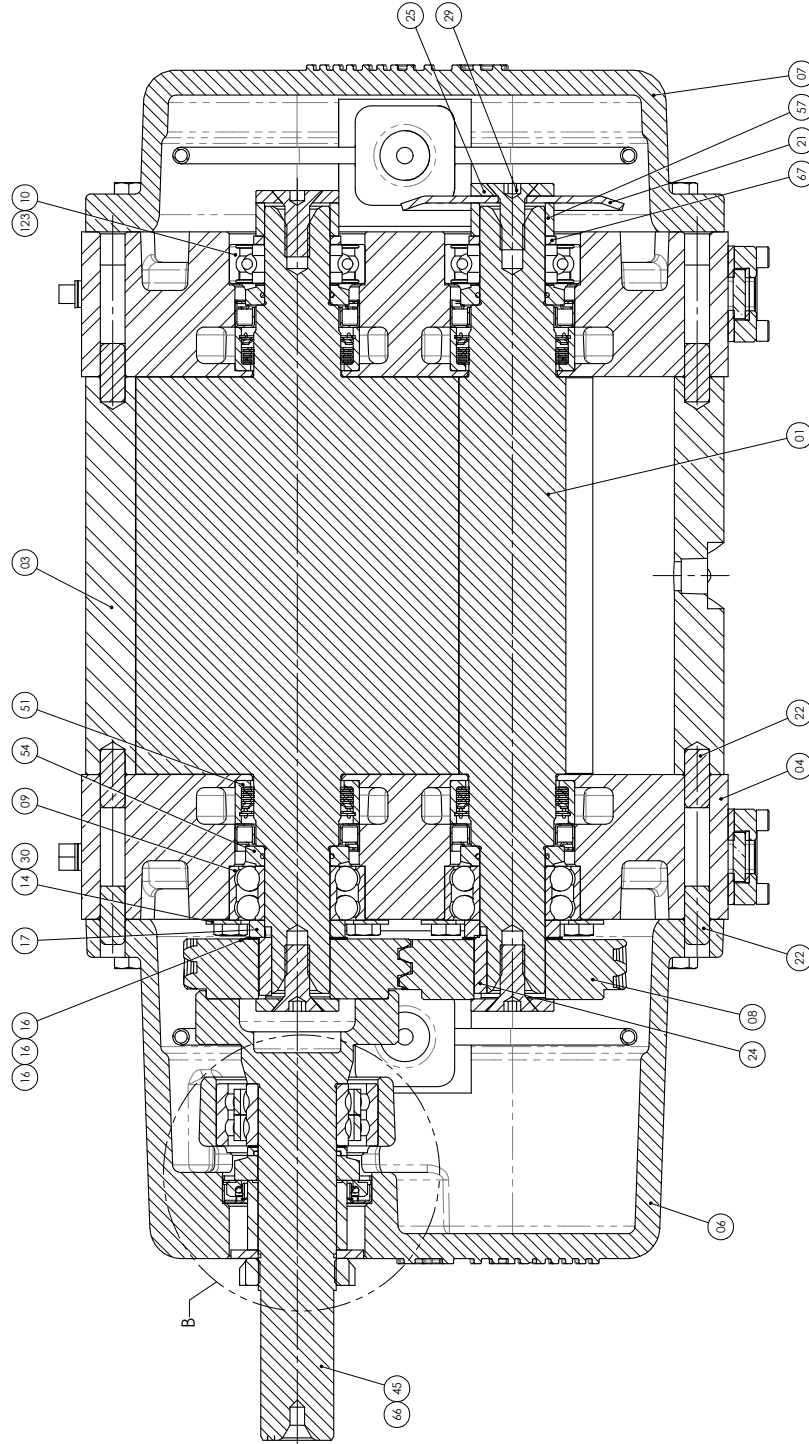

Model EX3200 - Double Envelope

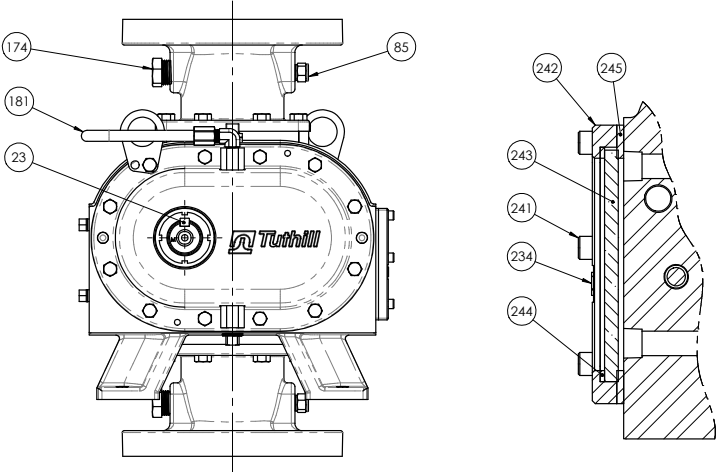
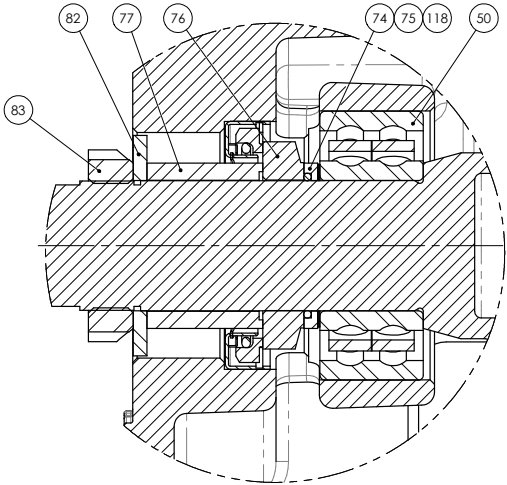
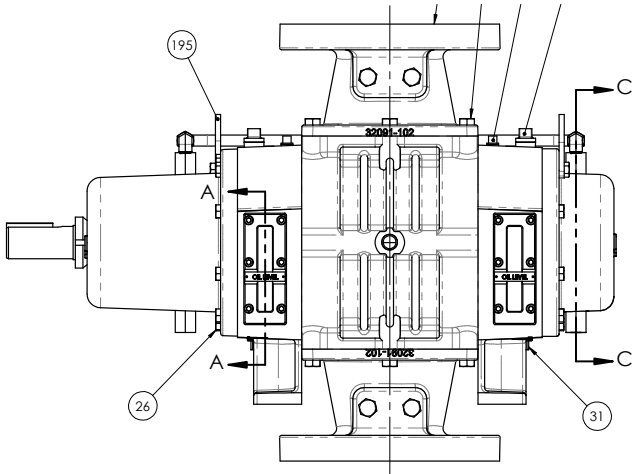
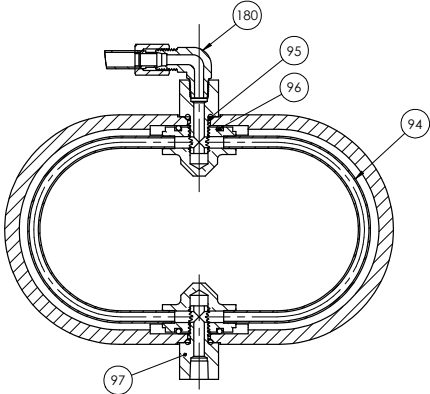

Model EX3200 - Double Envelope - Dimensions

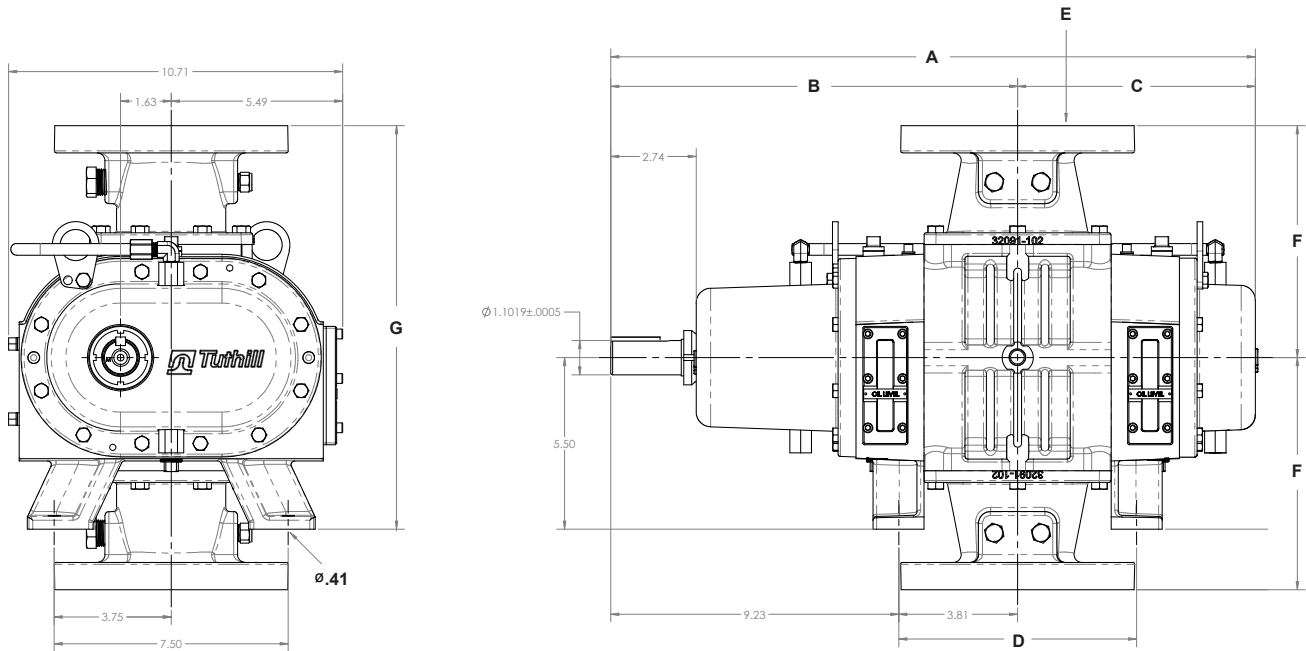

| EX3200 DIMENSIONS | | | | | | | |
|-------------------|-----------------------|-----------------------|----------------------|-----------------------|------------------|----------------------|-----------------------|
| MODEL | A | B | C | D | E | F | G |
| EX3204 | 18.66 in. (474 mm) | 12.04 in. (306 mm) | 6.62 in. (168 mm) | 5.62 in. (143 mm) | 2" FLG 50 DN | 5.82 in. (148 mm) | 12.13 in. (308 mm) |
| EX3206 | 20.66 in. (525 mm) | 13.04 in. (331 mm) | 7.62 in. (193 mm) | 7.62 in. (193 mm) | 3" FLG 80 DN | 7.44 in. (189 mm) | 12.94 in. (329 mm) |
| EX3210 | 24.66 in. (626 mm) | 15.04 in. (382 mm) | 9.62 in. (244 mm) | 11.62 in. (295 mm) | 4" FLG 100 DN | 7.44 in. (189 mm) | 12.94 in. (329 mm) |

Parts List for Model EX3200 Series - Double Envelope

| ITEM NO. | PART DESCRIPTION | QTY. |
|----------|-----------------------|------|
| 1 | Rotor | 2 |
| 3 | Housing | 1 |
| 4 | End Plate | 2 |
| 6 | Drive End Cover | 1 |
| 7 | Free End Cover | 1 |
| 8 | Timing Gear Set | 1 |
| 9 | Bearing, Drive End | 2 |
| 10 | Bearing, Free End | 2 |
| 14 | Bearing Retainer | 2 |
| 16 | Shim | 2 |
| 16 | Shim | 6 |
| 16 | Shim | 2 |
| 17 | Spacer | 2 |
| 21 | Oil Slinger | 1 |
| 22 | Dowel Pin | 6 |
| 23 | Drive Shaft Key | 1 |
| 24 | Gear Key | 2 |
| 25 | Rotor Shaft Washer | 4 |
| 26 | Cap Screw | 23 |
| 29 | Cap Screw | 4 |
| 30 | Cap Screw | 8 |
| 31 | Magnetic Pipe Plug | 2 |
| 38 | Port | 2 |
| 40 | Cap Screw | 20 |
| 42 | Name Plate | 1 |
| 45 | Drive Shaft | 1 |
| 50 | Bearing | 1 |
| 51 | Labyrinth Seal | 4 |
| 54 | Machanical Seal | 4 |
| 57 | Spacer | 2 |
| 66 | Cap Screw | 2 |
| 67 | Spacer | 2 |
| 74 | Spacer | 1 |
| 75 | O-Ring | 1 |
| 76 | Drive Shaft Face Seal | 1 |

| ITEM NO. | PART DESCRIPTION | QTY. |
|----------|--------------------|------|
| 77 | Spacer | 1 |
| 82 | Washer | 1 |
| 83 | Lock Nut | 1 |
| 85 | Pipe Plug | 4 |
| 94 | Cooling Coil | 2 |
| 95 | O-Ring | 4 |
| 96 | O-Ring | 4 |
| 97 | Bush | 4 |
| 98 | Pipe Plug | 8 |
| 118 | Shim | 2 |
| 121 | Pipe Plug | 2 |
| 123 | Bearing Spacer | 2 |
| 174 | Pipe Plug | 2 |
| 180 | Elbow | 2 |
| 181 | Tubing | 1 |
| 195 | Lifting Lug | 2 |
| 234 | Oil Level Tag | 2 |
| 241 | Cap Screw | 12 |
| 242 | Sight Gauge Frame | 2 |
| 243 | Sight Gauge Glass | 2 |
| 244 | Sight Gauge Gasket | 2 |
| 245 | Frame Gasket | 2 |

Model EX3200 - Double Envelope - C-flange

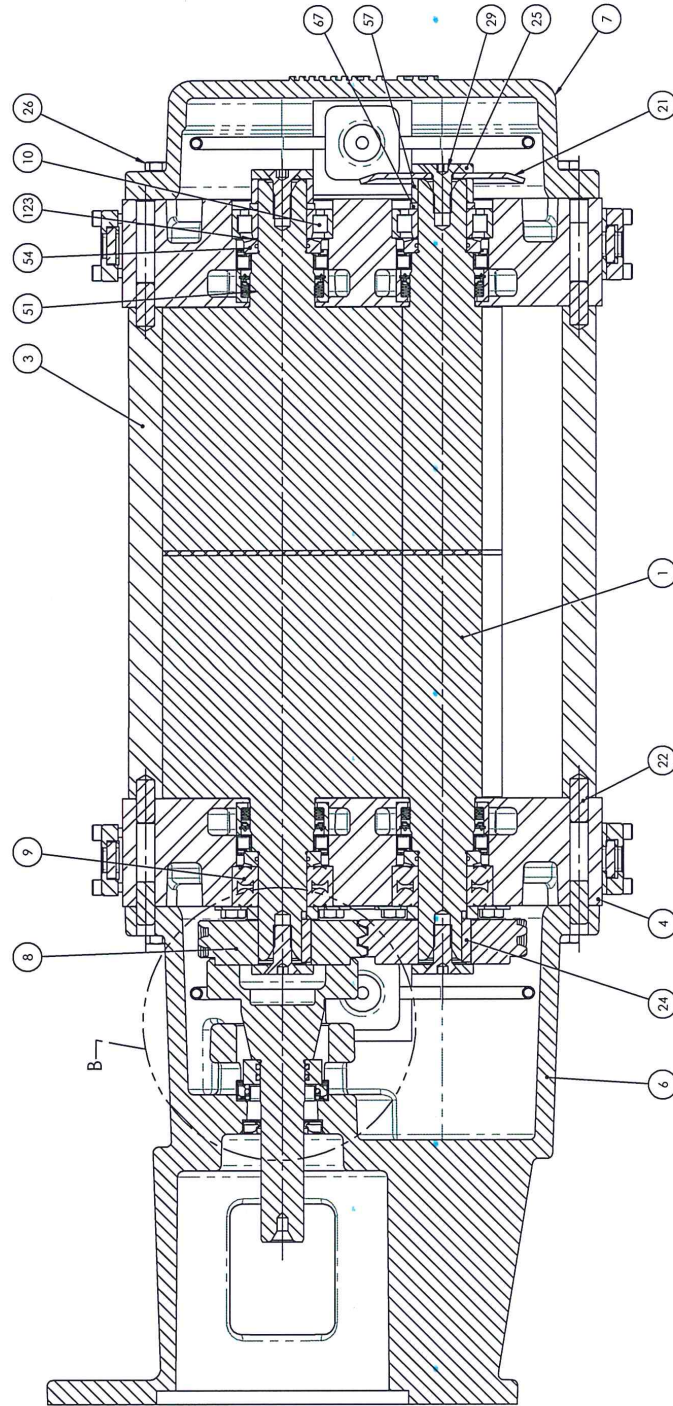

Model EX3200 - Double Envelope - C-Flange

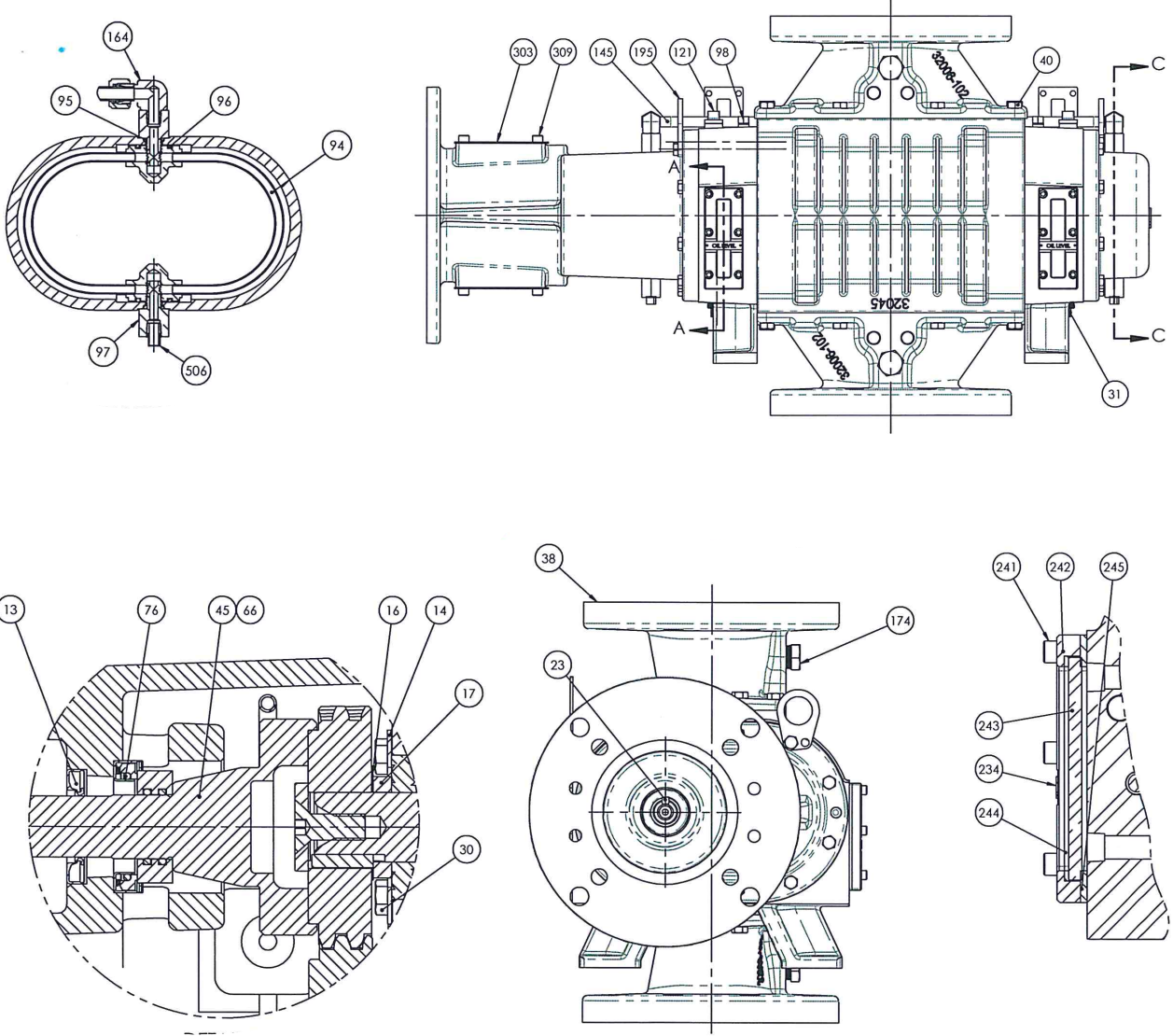

Model EX3200 - Double Envelope - C-flange - Dimensions

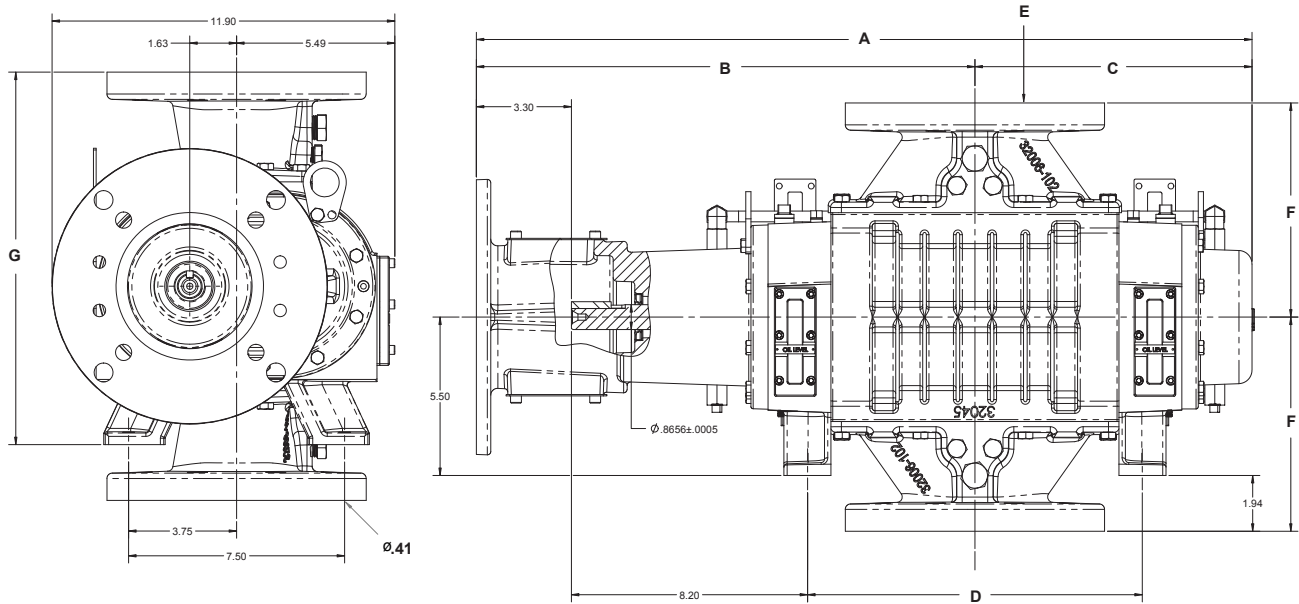

| EX3200 DIMENSIONS | | | | | | | |
|-------------------|-----------------------|-----------------------|----------------------|-----------------------|------------------|----------------------|-----------------------|
| MODEL | A | B | C | D | E | F | G |
| EX3204 | 20.93 in. (532 mm) | 14.31 in. (363 mm) | 6.62 in. (168 mm) | 6.62 in. (168 mm) | 2" FLG 50 DN | 5.82 in. (148 mm) | 12.13 in. (308 mm) |
| EX3206 | 22.93 in. (582 mm) | 15.31 in. (389 mm) | 7.62 in. (193 mm) | 7.62 in. (193 mm) | 3" FLG 80 DN | 7.44 in. (189 mm) | 12.94 in. (329 mm) |
| EX3210 | 26.93 in. (684 mm) | 17.31 in. (440 mm) | 9.62 in. (244 mm) | 11.62 in. (295 mm) | 4" FLG 100 DN | 7.44 in. (189 mm) | 12.94 in. (329 mm) |

Parts List for Model EX3200 Series - Double Envelope - C-flange

| ITEM NO. | PART DESCRIPTION | QTY. |
|----------|--------------------|------|
| 1 | Rotor | 2 |
| 3 | Housing | 1 |
| 4 | End Plate | 2 |
| 6 | Drive End Cover | 1 |
| 7 | Free End Cover | 1 |
| 8 | Timing Gear | 1 |
| 9 | Bearing Drive End | 2 |
| 10 | Bearing Free End | 2 |
| 13 | Lip Seal | 1 |
| 14 | Bearing Retainer | 2 |
| 16 | Shim | 2 |
| 16 | Shim | 6 |
| 16 | Shim | 2 |
| 17 | Spacer | 2 |
| 21 | Oil Slinger | 1 |
| 22 | Dowel Pin | 6 |
| 23 | Drive Shaft Key | 1 |
| 24 | Gear Key | 2 |
| 25 | Rotor Shaft Washer | 4 |
| 26 | Cap Screw | 24 |
| 29 | Cap Screw | 4 |
| 30 | Cap Screw | 8 |
| 31 | Magnetic Pipe Plug | 2 |
| 38 | Port | 2 |
| 40 | Cap Screw | 24 |
| 42 | Name Plate | 1 |
| 45 | Drive Shaft | 1 |
| 51 | Labyrinth Seal | 4 |
| 54 | Mechanical Seal | 4 |
| 57 | Spacer | 2 |
| 66 | Cap Screw | 2 |
| 67 | Spacer | 2 |
| 76 | Drive Shaft Seal | 1 |
| 85 | Pipe Plug | 4 |
| 94 | Cooling Coil | 2 |

| ITEM NO. | PART DESCRIPTION | QTY. |
|----------|--------------------|------|
| 95 | O-Ring | 4 |
| 96 | O-Ring | 4 |
| 97 | Bush | 4 |
| 98 | Pipe Plug | 4 |
| 121 | Pipe Plug | 2 |
| 123 | Bearing Spacer | 2 |
| 145 | Tubing | 1 |
| 164 | Elbow | 2 |
| 174 | Pipe Plug | 2 |
| 195 | Lifting Lug | 2 |
| 234 | Oil Level Tag | 4 |
| 241 | Cap Screw | 12 |
| 242 | Sight Gauge Frame | 2 |
| 243 | Sight Gauge Glass | 2 |
| 244 | Sight Gauge Gasket | 2 |
| 245 | Frame Gasket | 2 |
| 303 | C-flange Cover | 2 |
| 309 | Cap Screw | 8 |
| 506 | Cap Plug | 2 |

Model EX4000 - Double Envelope

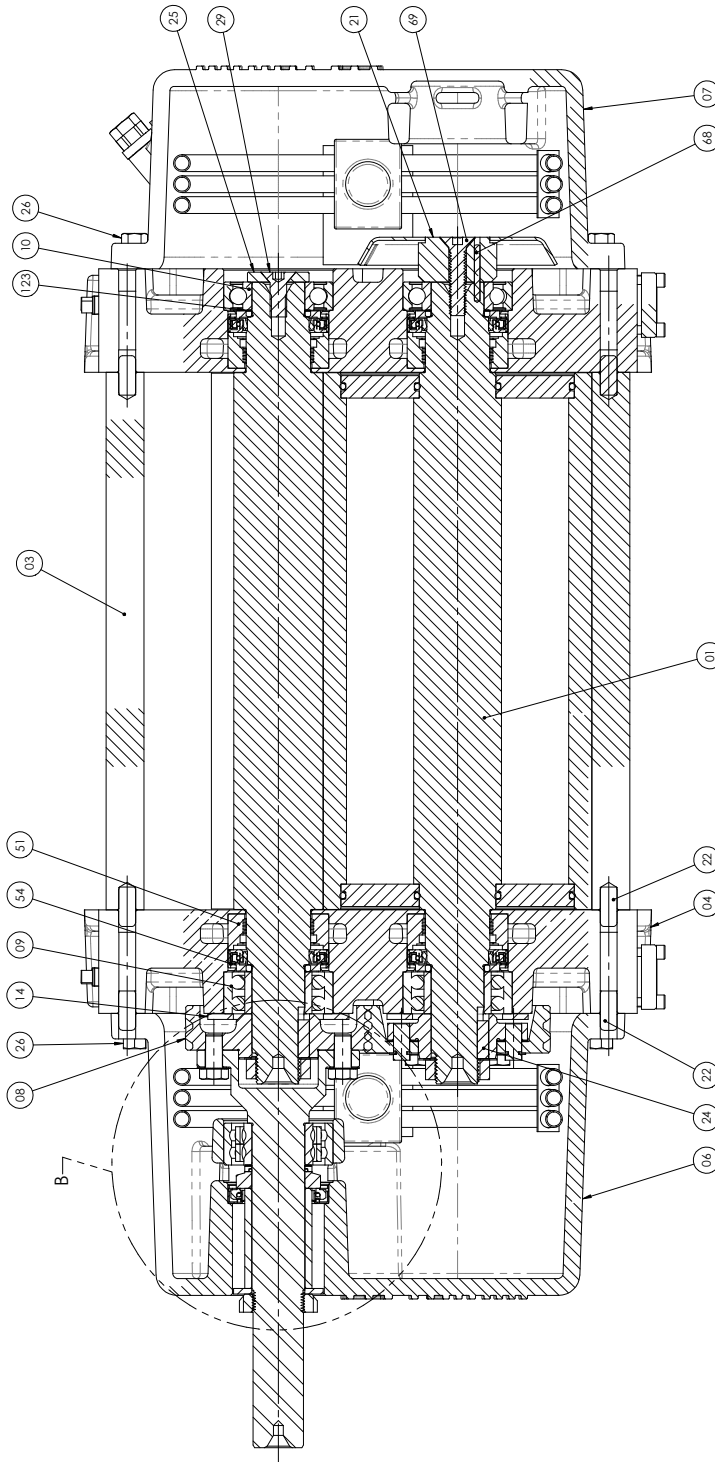

Model EX4000 - Double Envelope

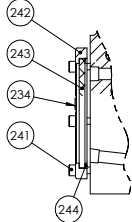
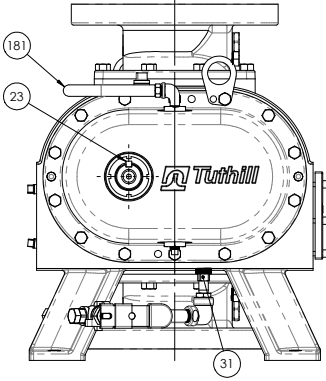
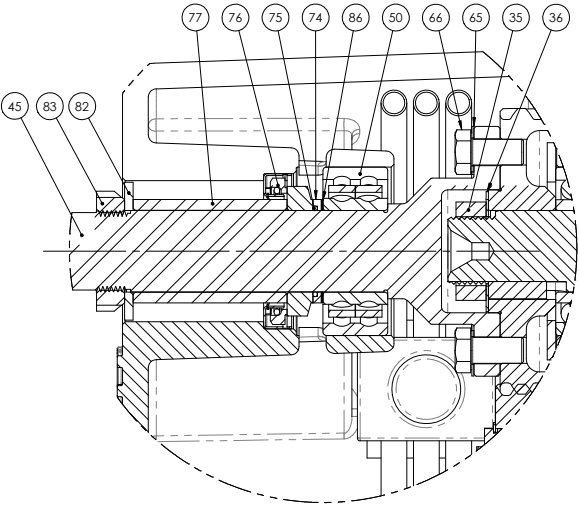
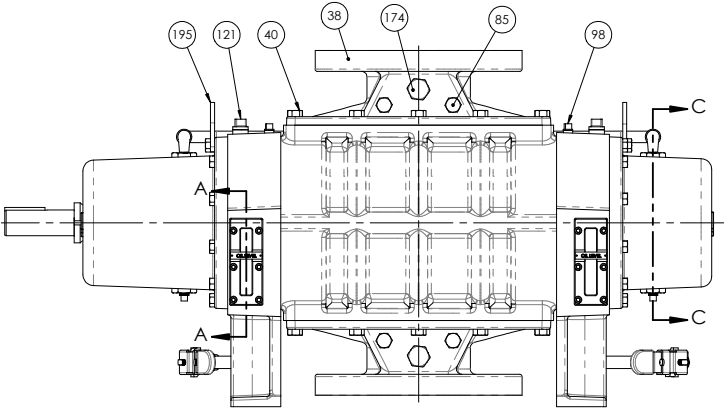
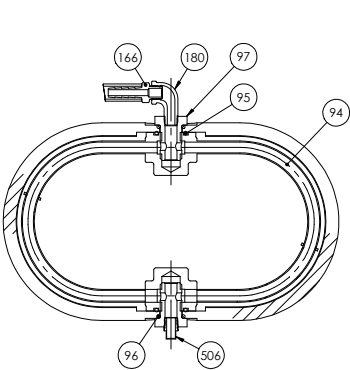

Model EX4000 - Double Envelope - Dimensions

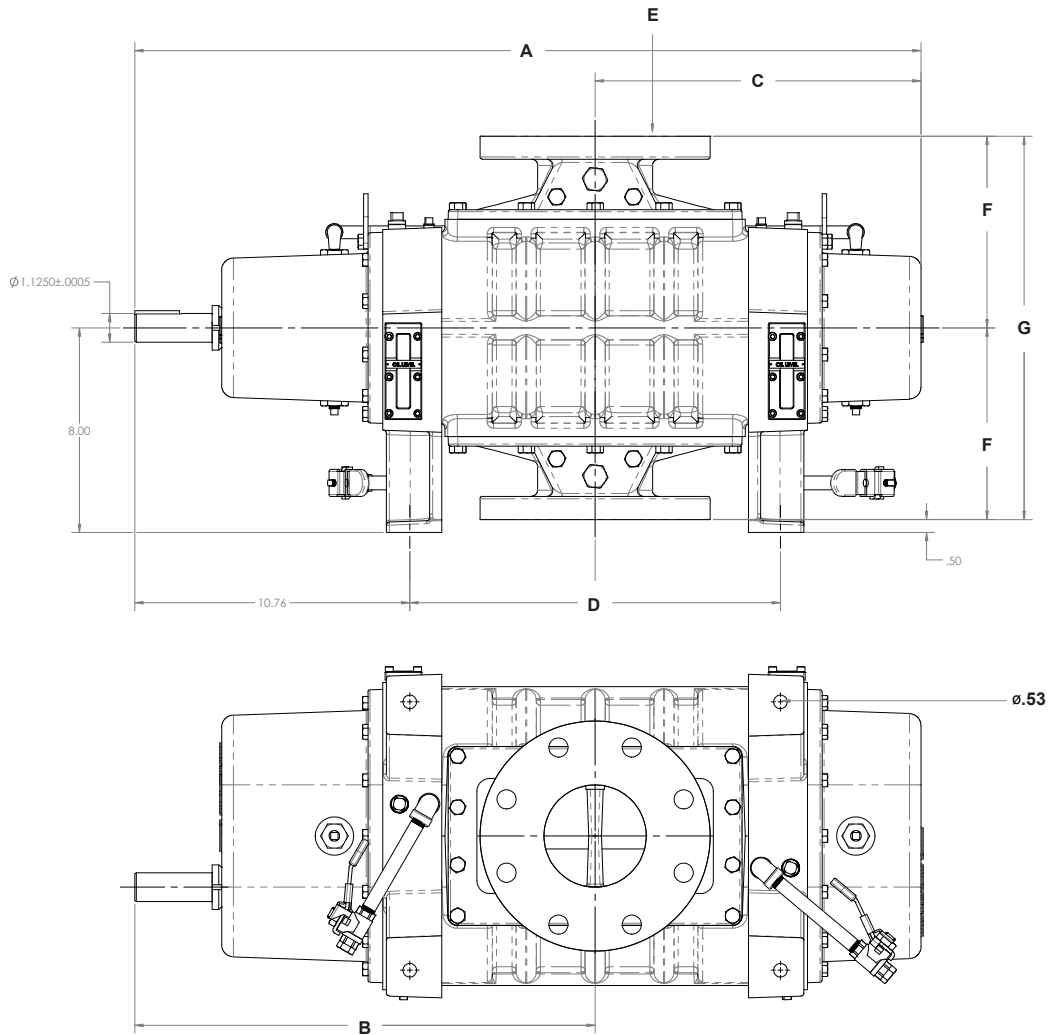

| EX4000 DIMENSIONS | | | | | | | |
|-------------------|-----------------------|-----------------------|-----------------------|-----------------------|-----------------|----------------------|-----------------------|
| MODEL | A | B | C | D | E | F | G |
| EX4009 | 27.76 in. (705 mm) | 16.51 in. (419 mm) | 11.25 in. (286 mm) | 11.50 in. (292 mm) | 4"FLG 100 DN | 7.50 in. (191 mm) | 15.50 in. (394 mm) |
| EX4012 | 30.76 in. (781 mm) | 18.01 in. (457 mm) | 12.75 in. (324 mm) | 14.50 in. (368 mm) | 4"FLG 100 DN | 7.50 in. (191 mm) | 15.50 in. (394 mm) |

Parts List for Model EX4000 Series - Double Envelope

| ITEM NO. | PART DESCRIPTION | QTY. |
|----------|---------------------|------|
| 1 | Rotor | 2 |
| 3 | Housing | 1 |
| 4 | End Plate | 2 |
| 6 | Drive End Cover | 1 |
| 7 | Free End Cover | 1 |
| 8 | Timing Gear Set | 1 |
| 9 | Bearing Drive End | 2 |
| 10 | Bearing Free End | 2 |
| 14 | Bearing Retainer | 2 |
| 21 | Oil Slinger | 1 |
| 22 | Dowel Pin | 6 |
| 23 | Drive Shaft Key | 1 |
| 24 | Gear Key | 2 |
| 25 | Rotor Shaft Washer | 1 |
| 26 | Cap Screw | 28 |
| 29 | Cap Screw | 1 |
| 31 | Magnetic Pipe Lug | 2 |
| 35 | Lock Nut | 2 |
| 36 | Lock Washer | 2 |
| 38 | Port | 2 |
| 40 | Cap Screw | 28 |
| 45 | Drive Shaft | 1 |
| 50 | Drive Shaft Bearing | 1 |
| 51 | Labyrinth Seal | 4 |
| 54 | Mechanical Seal | 4 |
| 62 | Cap Screw | 8 |
| 65 | Lock Plate | 2 |
| 66 | Cap Screw | 4 |
| 68 | Dowel Pin | 1 |
| 69 | Cap Screw | 1 |
| 74 | Spacer | 1 |
| 75 | O-Ring | 1 |
| 76 | Mechanical Seal | 1 |
| 77 | Spacer | 1 |
| 82 | Dust Washer | 1 |

| ITEM NO. | PART DESCRIPTION | QTY. |
|----------|--------------------|------|
| 83 | Lock Nut | 1 |
| 86 | Shim | 1 |
| 86 | Shim | 2 |
| 94 | Cooling Coil | 2 |
| 95 | O-Ring | 4 |
| 96 | O-Ring | 4 |
| 97 | Bush | 4 |
| 98 | Pipe Plug | 6 |
| 121 | Pipe Plug | 2 |
| 123 | Spacer | 2 |
| 174 | Pipe Plug | 2 |
| 180 | Elbow | 2 |
| 181 | Tubing | 1 |
| 195 | Lifting Lug | 2 |
| 234 | Oil Level Tag | 2 |
| 241 | Cap Screw | 12 |
| 242 | Sight Glass Frame | 2 |
| 243 | Sight Glass Window | 2 |
| 244 | Window Gasket | 2 |
| 506 | Cap Plug | 2 |

Model EX4000 - Double Envelope - C-flange

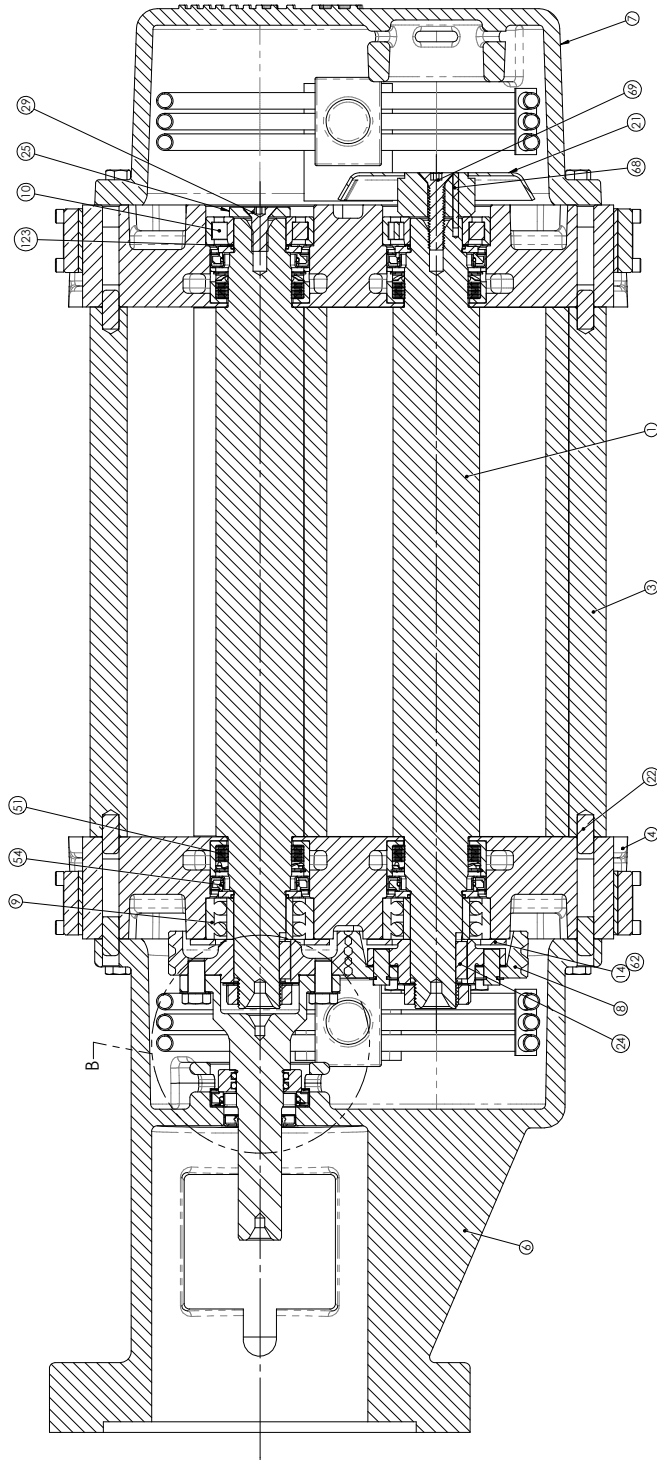

Model EX4000 - Double Envelope - C-flange

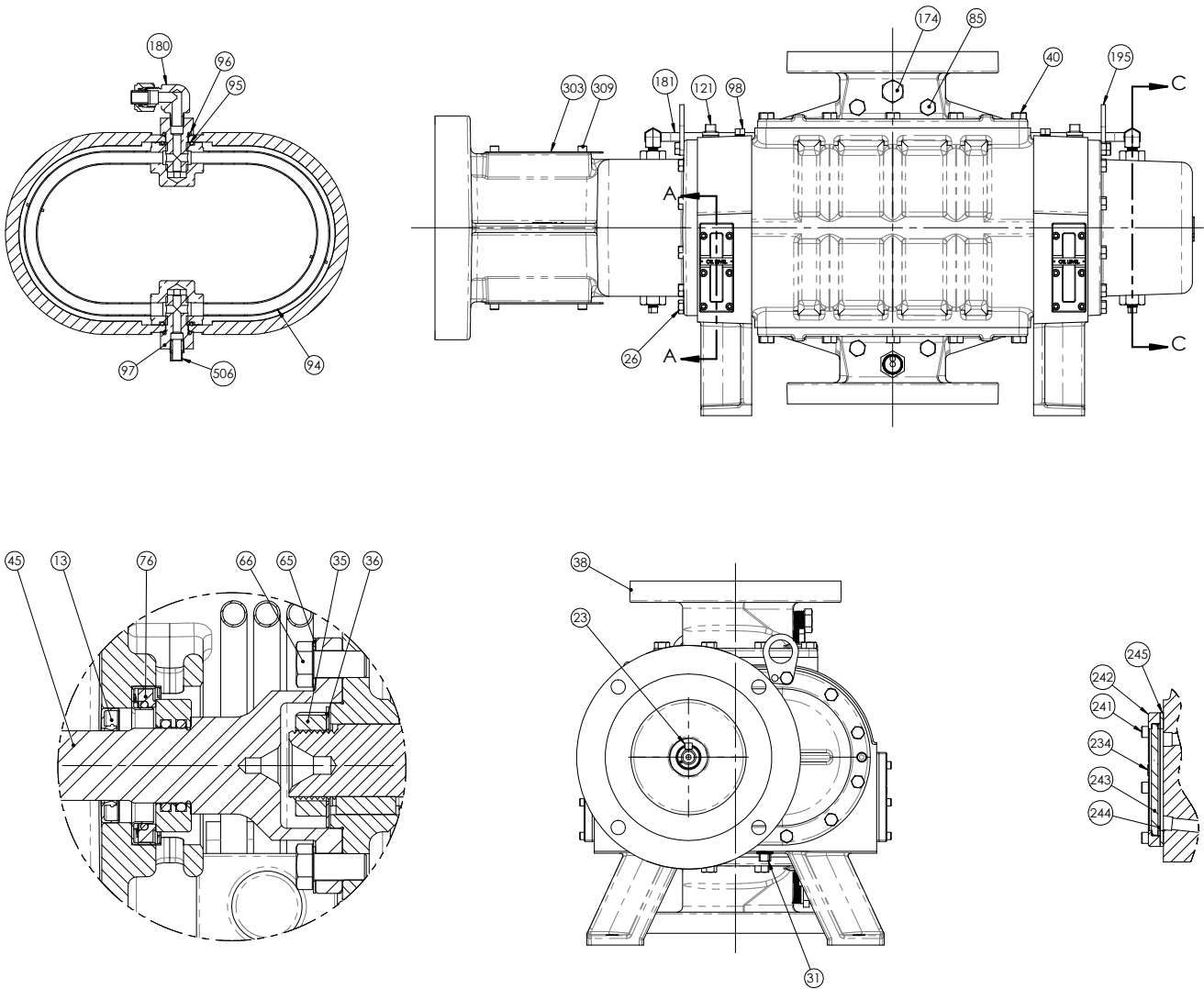

Model EX4000 - Double Envelope - C-flange - Dimensions

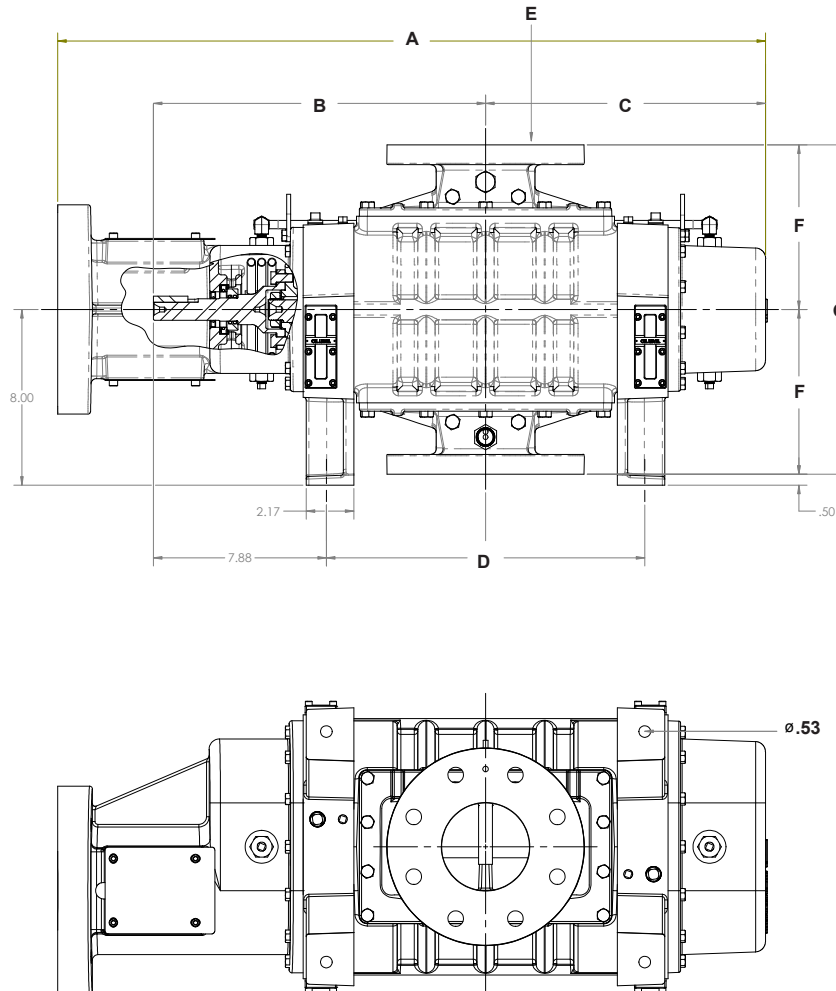

| EX4000 DIMENSIONS | | | | | | | |
|-------------------|-----------------------|-----------------------|-----------------------|-----------------------|-----------------|----------------------|-----------------------|
| MODEL | A | B | C | D | E | F | G |
| EX4009 | 29.24 in. (743 mm) | 13.63 in. (346 mm) | 11.25 in. (286 mm) | 11.50 in. (292 mm) | 4"FLG 100 DN | 7.50 in. (191 mm) | 15.50 in. (394 mm) |
| EX4012 | 32.24 in. (819 mm) | 15.13 in. (384 mm) | 12.75 in. (324 mm) | 14.50 in. (368 mm) | 4"FLG 100 DN | 7.50 in. (191 mm) | 15.50 in. (394 mm) |

Parts List for Model EX4000 Series - Double Envelope - C-flange

| ITEM NO. | PART DESCRIPTION | QTY. |
|----------|--------------------|------|
| 1 | Rotor | 2 |
| 3 | Housing | 1 |
| 4 | End Plate | 2 |
| 6 | Drive End Cover | 1 |
| 7 | Free End Cover | 1 |
| 8 | Timing Gear Set | 1 |
| 9 | Bearing Drive End | 2 |
| 10 | Bearing Free End | 2 |
| 13 | Lip Seal | 1 |
| 14 | Bearing Retainer | 2 |
| 21 | Oil Slinger | 1 |
| 22 | Dowel Pin | 6 |
| 23 | Drive Shaft Key | 1 |
| 24 | Gear Key | 2 |
| 25 | Rotor Shaft Washer | 1 |
| 26 | Cap Screw | 28 |
| 29 | Cap Screw | 1 |
| 31 | Magnetic Pipe Plug | 2 |
| 35 | Lock Nut | 2 |
| 36 | Lock Washer | 2 |
| 38 | Port | 2 |
| 40 | Cap Screw | 28 |
| 45 | Drive Shaft | 1 |
| 51 | Labyrinth Seal | 4 |
| 54 | Mechanical Seal | 4 |
| 62 | Cap Screw | 8 |
| 65 | Lock Plate | 2 |
| 66 | Cap Screw | 4 |
| 68 | Dowel Pin | 1 |
| 69 | Cap Screw | 1 |
| 76 | Mechanical Seal | 1 |
| 85 | Pipe Plug | 4 |
| 94 | Cooling Coil | 2 |
| 95 | O-Ring | 4 |
| 96 | O-Ring | 4 |

| ITEM NO. | PART DESCRIPTION | QTY. |
|----------|--------------------|------|
| 97 | Bush | 4 |
| 98 | Pipe Plug | 4 |
| 121 | Pipe Plug | 2 |
| 123 | Spacer | 2 |
| 174 | Pipe Plug | 1 |
| 180 | Elbow | 2 |
| 181 | Tubing | 1 |
| 104 | Lifting Lug | 2 |
| 234 | Oil Level Tag | 4 |
| 241 | Cap Screw | 12 |
| 242 | Sight Glass Frame | 2 |
| 243 | Sight Glass Window | 2 |
| 244 | Window Gasket | 2 |
| 245 | Frame Gasket | 2 |
| 303 | C-flange Cover | 2 |
| 309 | Cap Screw | 8 |
| 506 | Cap Plug | 2 |

Model EX5500 - Double Envelope

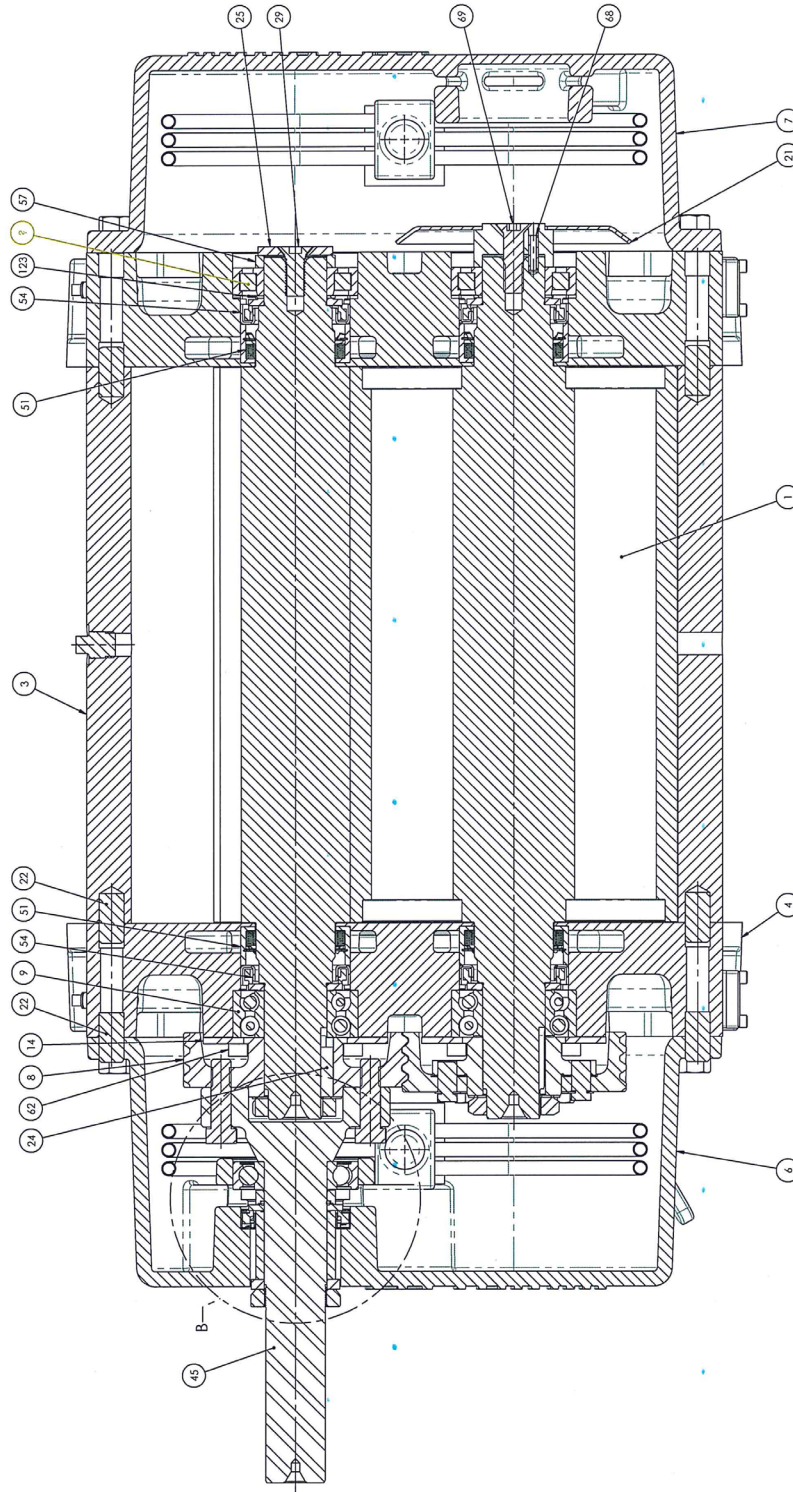

Model EX5500 - Double Envelope

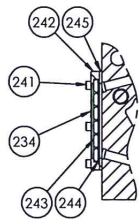
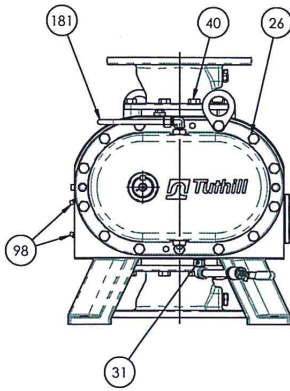
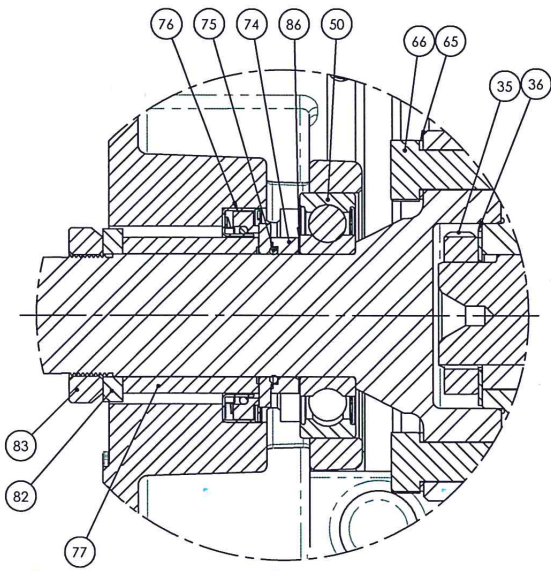
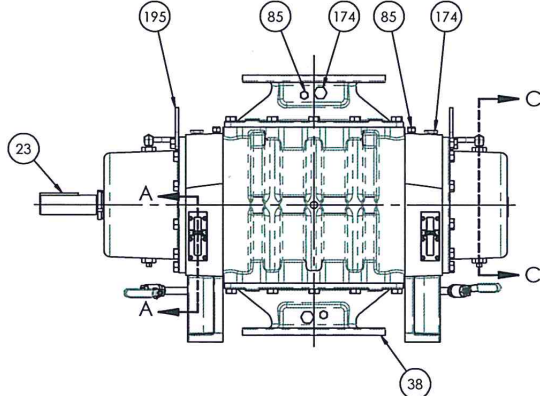
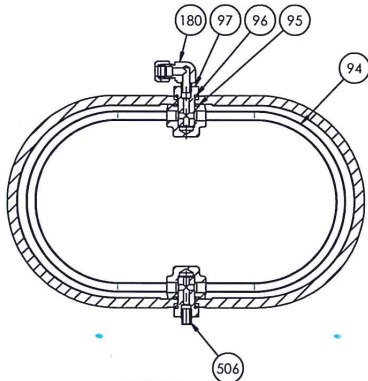

Model EX5500 - Double Envelope - Dimensions

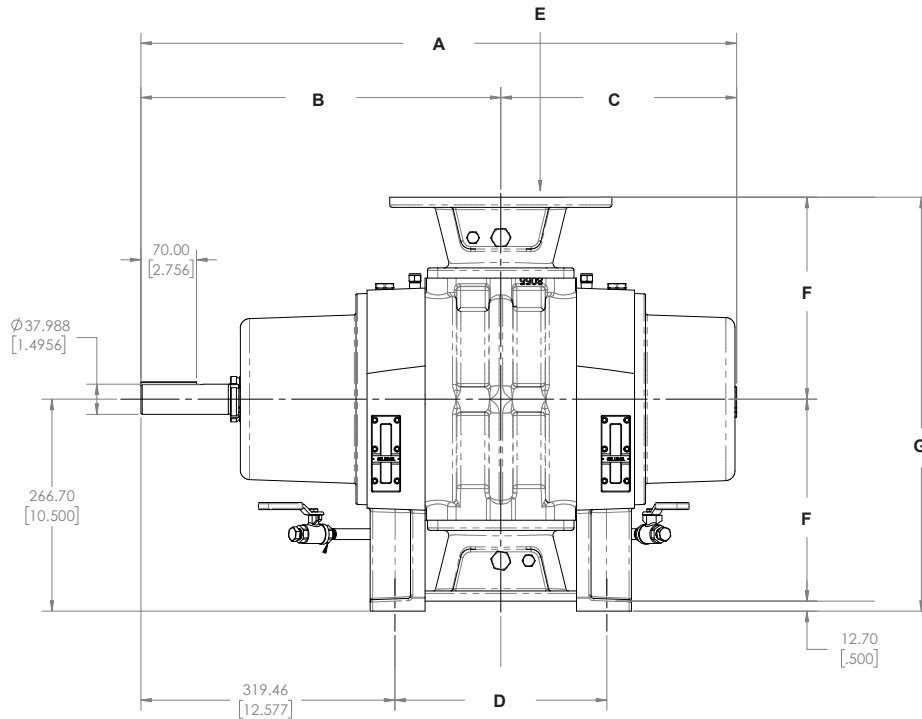

| EX5500 DIMENSIONS | | | | | | | |
|-------------------|------------------------|-----------------------|-----------------------|-----------------------|------------------|-----------------------|-----------------------|
| MODEL | A | B | C | D | E | F | G |
| EX5507 | 29.51 in. (750 mm) | 17.83 in. (453 mm) | 11.69 in. (297 mm) | 10.50 in. (267 mm) | 6"FLG 150 DN | 10.00 in. (254 mm) | 20.50 in. (521 mm) |
| EX5511 | 33.01 in. (838 mm) | 19.58 in. (497 mm) | 13.69 in. (348 mm) | 14.00 in. (368 mm) | 6"FLG 150 DN | 10.00 in. (254 mm) | 20.50 in. (521 mm) |
| EX5514 | 36.01 in. (915 mm) | 21.08 in. (535 mm) | 14.85 in. (377 mm) | 17.00 in. (445 mm) | 6"FLG 150 DN | 10.00 in. (254 mm) | 20.50 in. (521 mm) |
| EX5518 | 40.01 in. (1019 mm) | 23.08 in. (586 mm) | 16.85 in. (428 mm) | 21.00 in. (533 mm) | 8"FLG 200 DN | 10.00 in. (254 mm) | 20.50 in. (521 mm) |
| EX5524 | 46.01 in. (1169 mm) | 26.08 in. (662 mm) | 19.85 in. (504 mm) | 27.00 in. (686 mm) | 10"FLG 250 DN | 10.00 in. (254 mm) | 20.50 in. (521 mm) |

Parts List for Model EX5500 Series - Double Envelope

| ITEM NO. | PART DESCRIPTION | QTY. |
|----------|--------------------|------|
| 1 | Rotor | 2 |
| 3 | Housing | 1 |
| 4 | End Plate | 2 |
| 6 | Drive End Cover | 1 |
| 7 | Free End Cover | 1 |
| 8 | Timing Gear Set | 1 |
| 9 | Bearing, Drive End | 2 |
| 10 | Bearing, Free End | 2 |
| 14 | Bearing Retainer | 2 |
| 21 | Oil Slinger | 1 |
| 22 | Dowel Pin | 6 |
| 23 | Drive Shaft Key | 1 |
| 24 | Gear Key | 2 |
| 25 | Rotor Shaft Washer | 1 |
| 26 | Cap Screw, Hex HD | 28 |
| 29 | Cap Screw | 1 |
| 31 | Magnetic Pipe Plug | 2 |
| 35 | Lock Nut | 2 |
| 36 | Washer | 2 |
| 38 | Port Fitting | 2 |
| 40 | Cap Screw | 28 |
| 42 | Nameplate | 1 |
| 45 | Drive Shaft | 1 |
| 50 | Bearing | 1 |
| 51 | Labyrinth Seal | 4 |
| 54 | Mechanical Seal | 4 |
| 57 | Bearing Spacer | 1 |
| 62 | Cap Screw | 8 |
| 65 | Lock Plate | 2 |
| 66 | Cap Screw | 4 |
| 68 | Dowel Pin | 1 |
| 69 | Cap Screw | 1 |
| 74 | Spacer | 1 |
| 75 | O-Ring | 1 |
| 76 | Mechanical Seal | 1 |

| ITEM NO. | PART DESCRIPTION | QTY. |
|----------|------------------------------|------|
| 77 | Drive Shaft Face Seal Sleeve | 1 |
| 82 | Washer | 1 |
| 83 | Lock Nut | 1 |
| 85 | Pipe Plug | 4 |
| 86 | Shim | 2 |
| 94 | Cooling Coil | 2 |
| 95 | O-Ring | 4 |
| 96 | O-Ring | 4 |
| 97 | Bush | 4 |
| 98 | Pipe Plug | 4 |
| 123 | Bearing Spacer | 2 |
| 166 | Elbow | 2 |
| 174 | Pipe Plug | 4 |
| 180 | Adapter | 2 |
| 181 | Tubing | 1 |
| 195 | Lifting Lug | 2 |
| 234 | Oil Level Tag | 2 |
| 241 | Cap Screw | 12 |
| 242 | Sight Gauge Frame | 2 |
| 243 | Sight Gauge Glass Frame | 2 |
| 244 | Window Gasket | 2 |
| 245 | Frame Gasket | 2 |
| 506 | Caplug | 2 |

Model EX5500 - Double Envelope - C-Flange

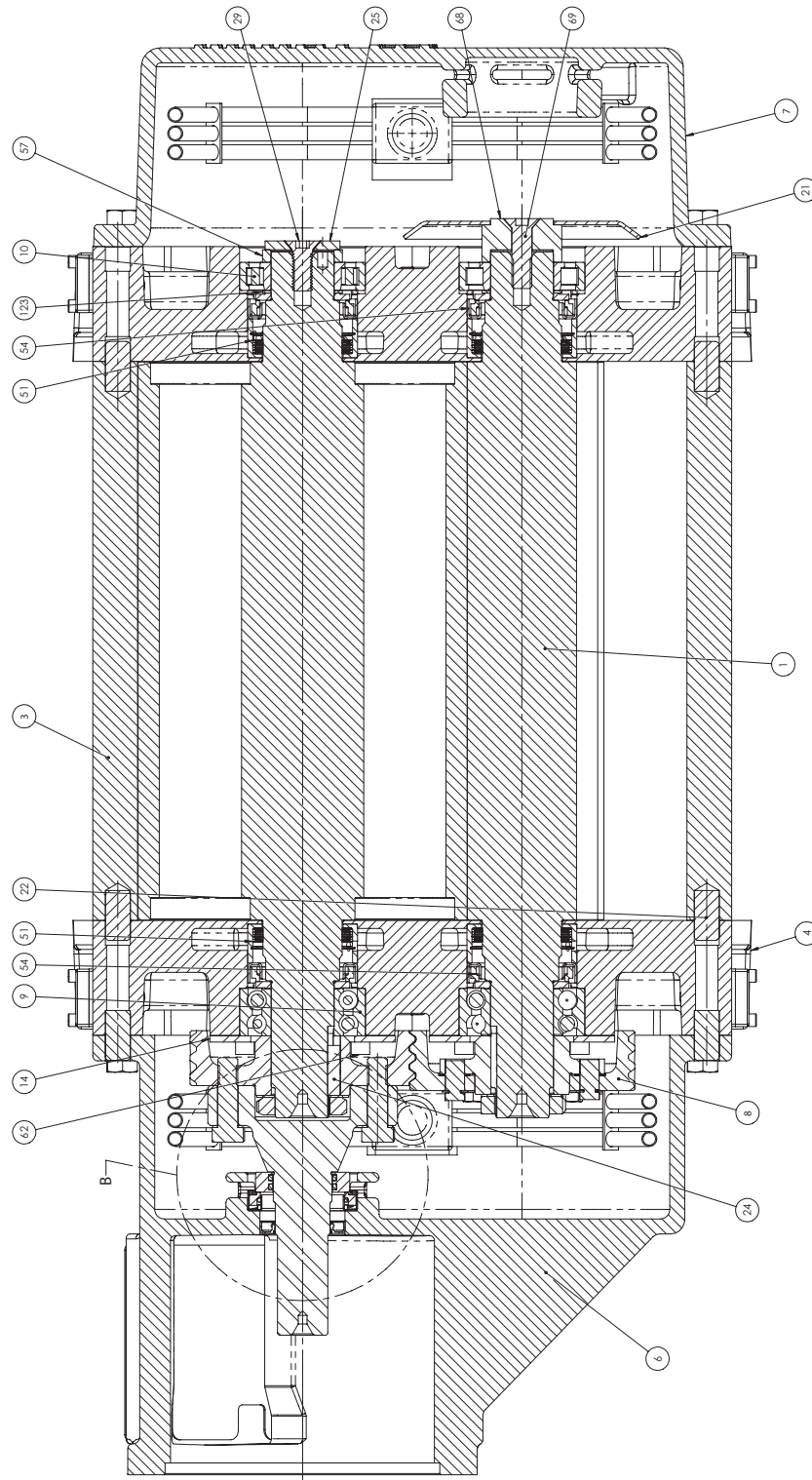

Model EX5500 - Double Envelope - C-Flange

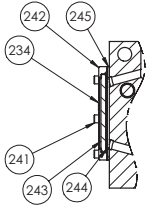
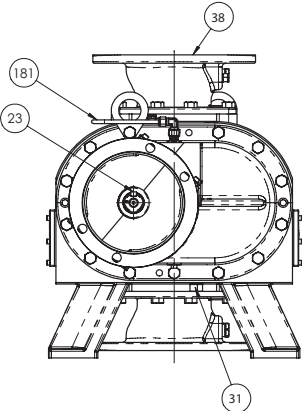
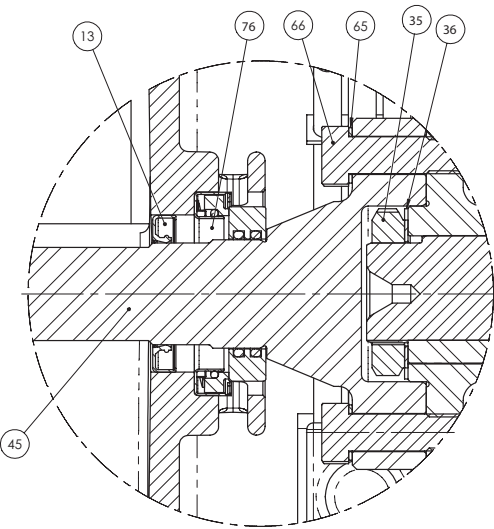
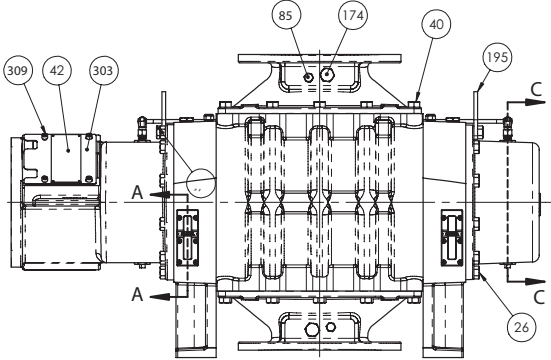
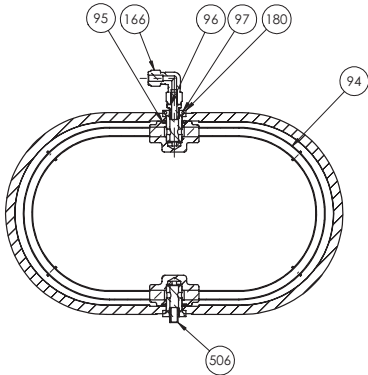

Model EX5500 - Double Envelope - C-Flange - Dimensions

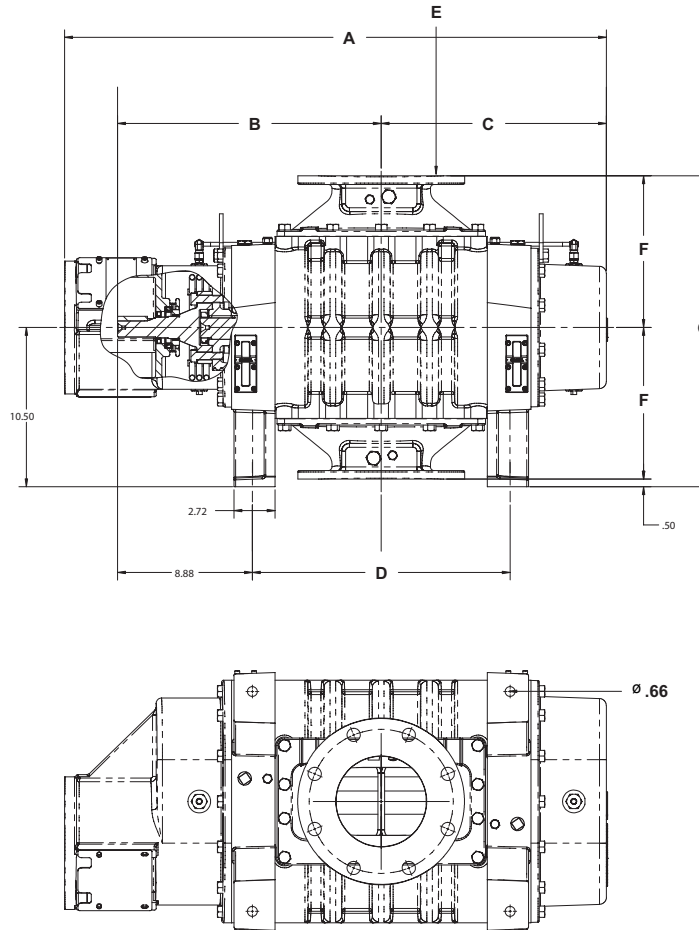

| EX5500 DIMENSIONS | | | | | | | |
|-------------------|------------------------|-----------------------|-----------------------|-----------------------|------------------|-----------------------|-----------------------|
| MODEL | A | B | C | D | E | F | G |
| EX5507 | 29.23 in. (742 mm) | 14.14 in. (359 mm) | 11.69 in. (297 mm) | 10.50 in. (267 mm) | 6"FLG 150 DN | 10.00 in. (254 mm) | 20.50 in. (521 mm) |
| EX5511 | 32.73 in. (831 mm) | 15.89 in. (404 mm) | 13.69 in. (348 mm) | 14.00 in. (368 mm) | 6"FLG 150 DN | 10.00 in. (254 mm) | 20.50 in. (521 mm) |
| EX5514 | 35.73 in. (908 mm) | 17.39 in. (535 mm) | 14.85 in. (377 mm) | 17.00 in. (445 mm) | 6"FLG 150 DN | 10.00 in. (254 mm) | 20.50 in. (521 mm) |
| EX5518 | 39.73 in. (1009 mm) | 21.39 in. (543 mm) | 16.85 in. (428 mm) | 21.00 in. (533 mm) | 8"FLG 200 DN | 10.00 in. (254 mm) | 20.50 in. (521 mm) |
| EX5524 | 45.73 in. (1143 mm) | 27.39 in. (696 mm) | 19.85 in. (377 mm) | 27.00 in. (686 mm) | 10"FLG 250 DN | 10.00 in. (254 mm) | 20.50 in. (521 mm) |

Parts List for Model EX5500 - Double Envelope - C-flange

| ITEM NO. | PART DESCRIPTION | QTY |
|----------|----------------------|-----|
| 1 | Rotor | 2 |
| 3 | Housing | 1 |
| 4 | End Plate | 2 |
| 6 | Drive End Cover | 1 |
| 7 | Free End Cover | 1 |
| 8 | Timing Gear Set | 1 |
| 9 | Bearing, Drive End | 2 |
| 10 | Bearing, Free End | 2 |
| 13 | Lip Seal | 1 |
| 14 | Bearing Retainer | 2 |
| 21 | Oil Slinger Assembly | 1 |
| 22 | Dowel Pins | 6 |
| 23 | Drive Shaft Key | 1 |
| 24 | Gear Key | 2 |
| 25 | Rotor Shaft Washer | 1 |
| 26 | Cap Screw | 28 |
| 29 | Flat Socket Screw | 1 |
| 31 | Magnetic Pipe Plug | 2 |
| 36 | Lock Washer | 2 |
| 38 | Port Fitting | 2 |
| 42 | Name Plate | 1 |
| 45 | Drive Shaft | 1 |
| 51 | Labyrinth Seal | 4 |
| 52 | Oil Filter Spacer | 1 |
| 54 | Mechanical Seal | 4 |
| 57 | Spacer | 1 |
| 62 | Cap Screw | 8 |
| 66 | Screw | 4 |
| 69 | Cap Screw | 1 |
| 76 | Mechanical Seal | 1 |
| 85 | Pipe Plug | 6 |
| 94 | Cooling Coil | 2 |
| 95 | O-Ring | 4 |
| 96 | O-Ring | 4 |

| ITEM NO. | PART DESCRIPTION | QTY |
|----------|--------------------|-----|
| 97 | Bush | 4 |
| 123 | Bearing Spacer | 2 |
| 166 | Elbow | 2 |
| 174 | Pipe Plug | 4 |
| 180 | Adapter | 2 |
| 195 | Lifting Lug | 2 |
| 234 | Oil Level Tag | 4 |
| 241 | Cap Screw | 12 |
| 242 | Sight Glass Frame | 2 |
| 243 | Sight Glass Window | 2 |
| 244 | Window Gasket | 2 |
| 245 | Frame Gasket | 2 |
| 303 | Cover Plate | 2 |
| 309 | Cap Screw | 8 |
| 506 | Caplug | 2 |

C-Flange Vacuum Booster Motor Adapter Kit (NEMA) – For EX5500 Series Only

5528 NEMA ADAPTER KIT

| KIT PART NUMBER | DESCRIPTION | MOTOR FRAME | ITEM NUMBER | | | |
|-----------------|------------------------------------------------------------|--------------|-----------------------|--------------------------------------|---------------------------------|------------------------------------|
| | | | 1 ADAPTER PART QTY | 2 ADAPTER MOUNTING CAP SCREWS QTY | 3 COUPLING INCLUDED YES / NO | 4 MOTOR MOUNTING CAP SCREWS QTY |
| 55228-210TC | C-Flange 213TC & 215TC Frame Size NEMA Adapter with screws | 213TC/215TC | 1 | 4 | No - ATEX Coupling Required | 4 |
| 55228-250TC | C-Flange 254TC & 256TC Frame Size NEMA Adapter with screws | 254TC/256TC | 1 | 4 | No - ATEX Coupling Required | 4 |
| 55228-280TSC | C-Flange 284TC & 286TC Frame Size NEMA Adapter with screws | 284TC/286TSC | 1 | 4 | No - ATEX Coupling Required | 4 |

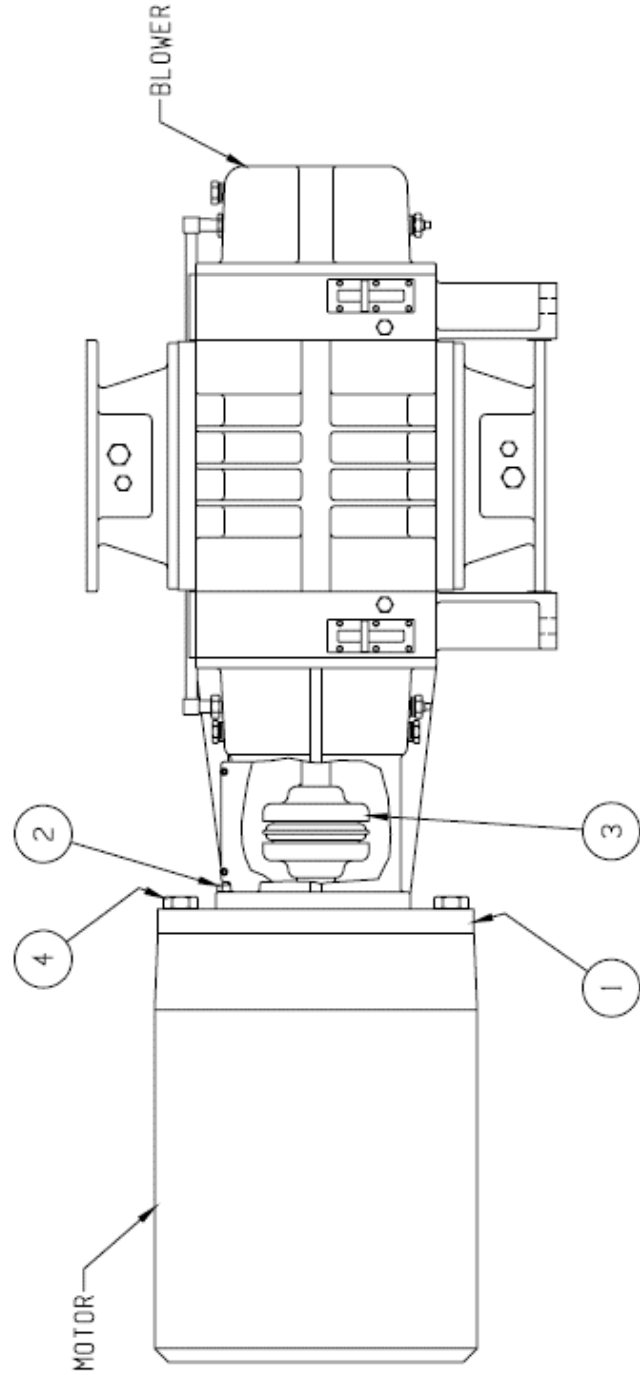

C-Flange Vacuum Booster Motor Adapter Kit (IEC) – For EX5500 Series Only

55227 IEC ADAPTER KIT

| KIT PART NUMBER | DESCRIPTION | MOTOR FRAME | ITEM NUMBER | | | | | |
|-----------------|---------------------------------------------------------|-------------|------------------|--------------------------------|-----------------------------|-------------------------------|-------------------------|-------------------------------|
| | | | 1 | 2 | 3 | 4 | 5 | 6 |
| 55227-132 | C-Flange 132S Frame Size IEC Adapter with screws | 132S | ADAPTER PART QTY | ADAPTER MOUNTING CAP SCREW QTY | COUPLING INCLUDED YES / NO | MOTOR MOUNTING CAP SCREWS QTY | MOTOR MOUNTING NUTS QTY | MOTOR MOUNTING LOCKWASHER QTY |
| 55227-160 | C-Flange 160L & 160M Frame Size IEC Adapter with screws | 160L/160M | 1 | 4 | No - ATEX Coupling Required | 4 | 4 | 4 |
| 55227-180 | C-Flange 180L & 180M Frame Size IEC Adapter with screws | 180L/180M | 1 | 4 | No - ATEX Coupling Required | 4 | 4 | 4 |

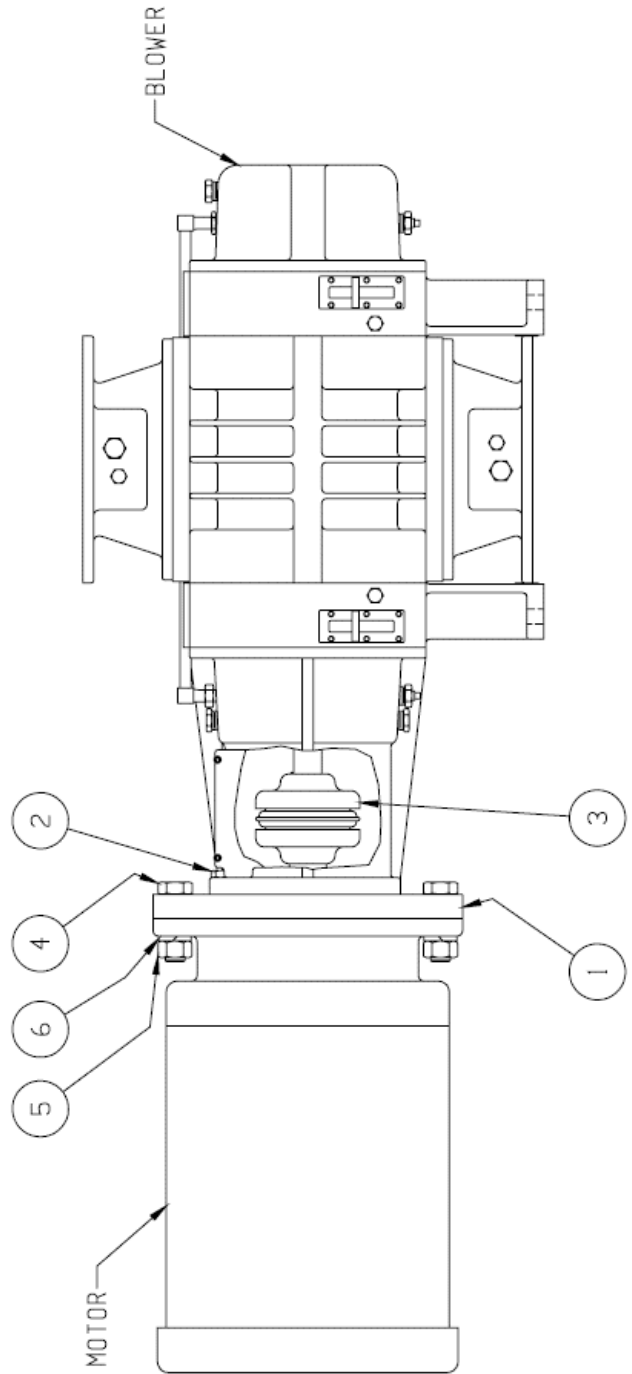

WARRANTY – BLOWER PRODUCTS

Subject to the terms and conditions hereinafter set forth and set forth in General Terms of Sale, M-D Pneumatics (the Seller) warrants products and parts of its manufacture, when shipped, and its work (including installation and start-up) when performed, will be of good quality and will be free from defects in material and workmanship. This warranty applies only to Seller's equipment, under use and service in accordance with seller's written instructions, recommendations and ratings for installation, operating, maintenance and service of products, for a period as stated in the table below. Because of varying conditions of installation and operation, all guarantees of performance are subject to plus or minus 5% variation. (Non-standard materials are subject to a plus or minus 10% variation)

| PRODUCT TYPE | TYPE OF APPLICATION | |
|----------------------------------|---------------------------------------------------------------------------------------------------|--------------------------------------------------------------------------------------------------|
| | ATMOSPHERIC AIR OR PROCESS AIR WITHOUT LIQUIDS PRESENT | PROCESS GASES OTHER THAN AIR, OR ANY LIQUID INJECTED APPLICATION |
| New (Qx™ models only) | 30 months from date of shipment, or 24 months after initial startup date, whichever occurs first. | Consult Factory |
| New (all other models) | 24 months from date of shipment, or 18 months after initial startup date, whichever occurs first | 18 months from date of shipment, or 12 months after initial startup date, whichever occurs first |
| Repair | 12 months from date of shipment, or remaining warranty period, whichever is greater | 12 months from date of shipment, or remaining warranty period, whichever is greater |

THIS WARRANTY EXTENDS ONLY TO BUYER AND/OR ORIGINAL END USER, AND IN NO EVENT SHALL THE SELLER BE LIABLE FOR PROPERTY DAMAGE SUSTAINED BY A PERSON DESIGNATED BY THE LAW OF ANY JURISDICTION AS A THIRD PARTY BENEFICIARY OF THIS WARRANTY OR ANY OTHER WARRANTY HELD TO SURVIVE SELLER'S DISCLAIMER.

All accessories furnished by Seller but manufactured by others bear only that manufacturer's standard warranty.

All claims for defective products, parts, or work under this warranty must be made in writing immediately upon discovery and, in any event within one (1) year from date of shipment of the applicable item and all claims for defective work must be made in writing immediately upon discovery and in any event within one (1) year from date of completion thereof by Seller. Unless done with prior written consent of Seller, any repairs, alterations or disassembly of Seller's equipment shall void warranty. Installation and transportation costs are not included and defective items must be held for Seller's inspection and returned to Seller's Ex-works point upon request.

THERE ARE NO WARRANTIES, EXPRESSED, IMPLIED OR STATUTORY WHICH EXTEND BEYOND THE DESCRIPTION ON THE FACE HEREOF, INCLUDING WITHOUT LIMITATION, THE IMPLIED WARRANTIES OF MERCHANTABILITY AND FITNESS OF PURPOSE.

After Buyer's submission of a claim as provided above and its approval, Seller shall at its option either repair or replace its product, part, or work at the original Ex-works point of shipment, or refund an equitable portion of the purchase price.

The products and parts sold hereunder are not warranted for operation with erosive or corrosive material or those which may lead to build up of material within the product supplied, nor those which are incompatible with the materials of construction. The Buyer shall have no claim whatsoever and no product or part shall be deemed to be defective by reason of failure to resist erosive or corrosive action nor for problems resulting from build-up of material within the unit nor for problems due to incompatibility with the materials of construction.

Any improper use, operation beyond capacity, substitution of parts not approved by Seller, or any alteration or repair by others in such manner as in Seller's judgment affects the product materially and adversely shall void this warranty.

No employee or representative of Seller other than an Officer of the Company is authorized to change this warranty in any way or grant any other warranty. Any such change by an Officer of the Company must be in writing.

The foregoing is Seller's only obligation and Buyer's only remedy for breach of warranty, and except for gross negligence, willful misconduct and remedies permitted under the General Terms of Sale in the sections on CONTRACT PERFORMANCE, INSPECTION AND ACCEPTANCE and the PATENTS Clause hereof, the foregoing is BUYER'S ONLY REMEDY HEREUNDER BY WAY OF BREACH OF CONTRACT, TORT OR OTHERWISE, WITHOUT REGARD TO WHETHER ANY DEFECT WAS DISCOVERED OR LATENT AT THE TIME OF DELIVERY OF THE PRODUCT OR WORK. In no event shall Buyer be entitled to incidental or consequential damages. Any action for breach of this agreement must commence within one (1) year after the cause of action has occurred.

OPERATING DATA FORM / PRODUCT REGISTRATION

It is to the user's advantage to have the requested data filled in below and available in the event a problem should develop in the blower or the system. This information is also helpful when ordering spare parts.

| | | | | | |
|-----------------------|-------|---------------------------------------------------|-------|--------|-------|
| Model No. | _____ | V-Belt Size | _____ | Length | _____ |
| Serial No. | _____ | Type of Lubrication | _____ | | |
| Startup Date | _____ | _____ | | | |
| Pump RPM | _____ | Operating Vacuum | _____ | | |
| Pump Sheave Diameter | _____ | Any other Special Accessories Supplied or in use: | | | |
| Motor Sheave Diameter | _____ | _____ | | | |
| Motor RPM | _____ | HP | _____ | _____ | |

NOTES:

IMPORTANT

All blowers and vacuum boosters manufactured by M-D Pneumatics are date coded at time of shipment. In order to assure you of the full benefits of the product warranty, please complete, tear out and return the product registration card. You may also register your product online at www.mdpneumatis.com or contact Customer Service.

M-D Pneumatics®

**For Service & Repair, Technical
Support, or Product Sales contact:**

M-D Pneumatics
4840 West Kearney Street
Springfield, Missouri USA 65803-8702
O 417.865.8715 800.825.6937
F 417.865.2950
www.mdpneumatics.com



Manual 2025 Rev C p/n 002025 0000

04/21