

Models

KVO-400 KVO-500 KVO-700 KVO-900

Features

- Rugged and easy to service
- High efficiency
- Quiet, small footprint
- Equipped with NEMA Premium motor
- Easy maintenance and less downtime
- Air-cooled
- Ultimate vacuum for continuous operation of 0.375 Torr (with gas ballast), 0.075 without gas ballast
- Standard gas ballast
- Multistage exhaust filtration system

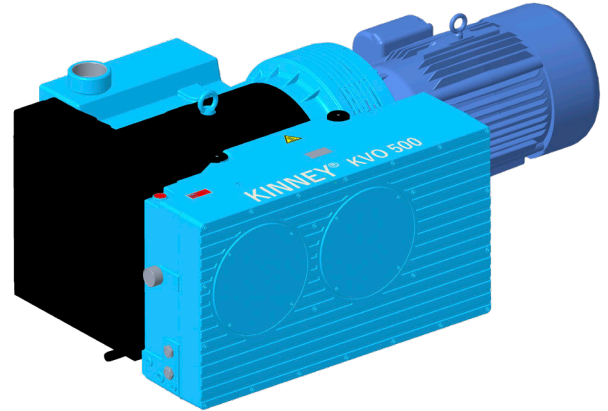

Specifications

Model	Nominal Displacement	Ultimate Pressure Without Gas Ballast	Ultimate Pressure With Gas Ballast	Motor	Rotation Speed	Oil Capacity	Pump Weight Includes Motor	Noise Level Max
	CFM / m3/hr	Torr / mbar	Torr / mbar	60Hz HP / 50Hz kW	60Hz / 50Hz	Gal. / Liters	Lbs. / kg	dB(A)
KVO-400	50Hz 235 / 400 60Hz 283 / 480	0.075 / 0.1	0.375 / 0.5	15 / 11	1140 / 950	3 / 11.5	1250 / 567	75
KVO-500	50Hz 324 / 550 60Hz 388 / 660	0.075 / 0.1	0.375 / 0.5	20 / 15	1140 / 950	4.4 / 17	1422 / 645	77
KVO-700	50Hz 412 / 700 60Hz 494 / 840	0.075 / 0.1	0.375 / 0.5	25 / 18.5	1140 / 950	4.4 / 17	1512 / 685	80
KVO-900	50Hz 489 / 830 60Hz 586 / 995	0.075 / 0.1	0.375 / 0.5	30 / 22.3	1140 / 950	5 / 19	1723 / 782	81

Typical Pumping Speed Curves NOTE: Curves represented with gas ballast open.

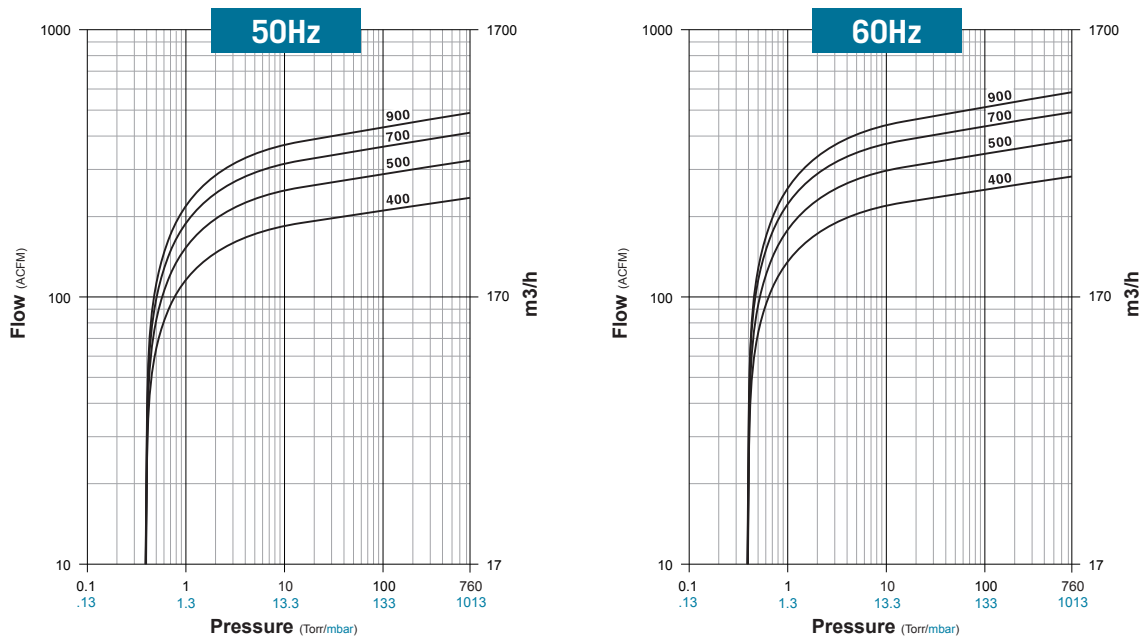

Dimensions

Values shown are approximate and should not be used for construction.
 Certified drawings are available through your local Kinney Sales Professional.

Models KVO-400, KVO-500, KVO-700, KVO-900

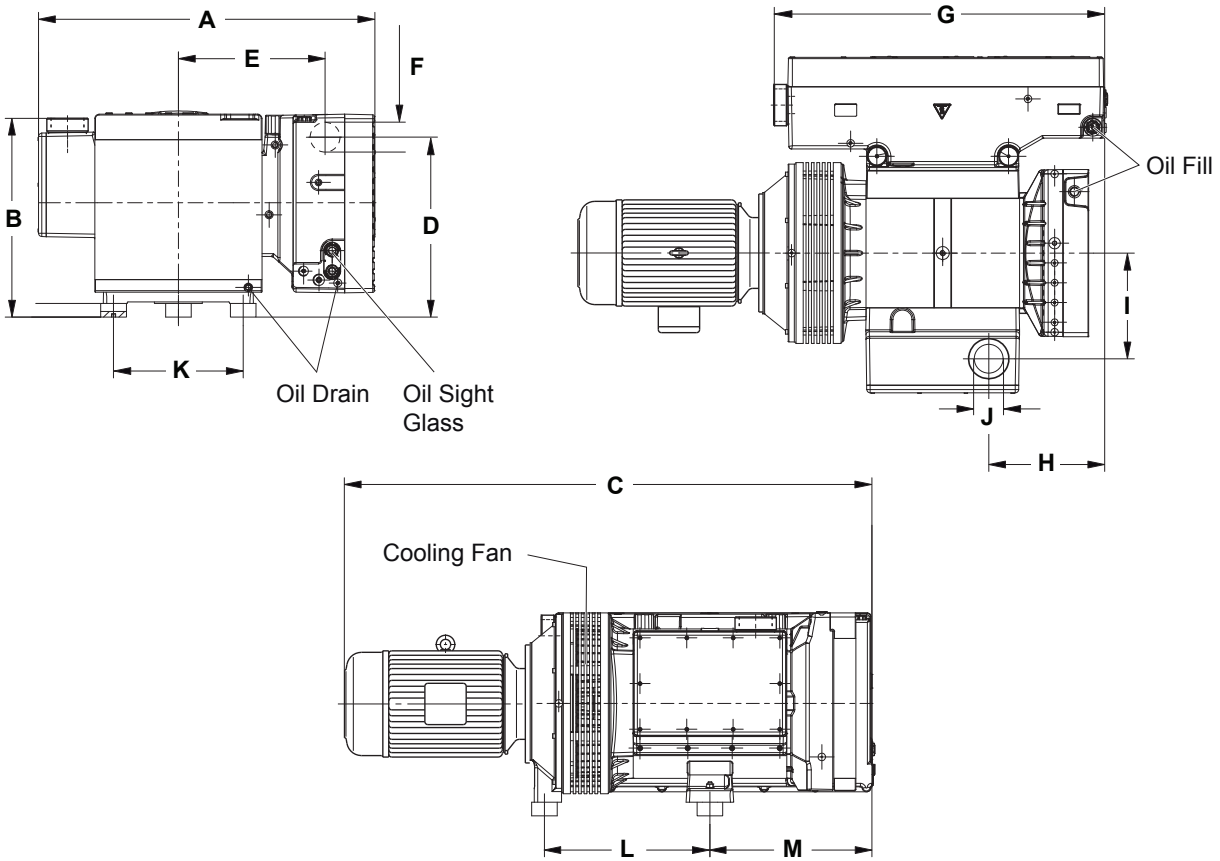

Model	A	B	C	D	E	F - EXHAUST	G	H	I	J - INLET	K	L	M
KVO-400 in. / mm	36.73 933	23.27 591	58.73 1492	20.28 515	14.65 372	3" FNPT	34.25 870	14.61 371	12.2 310	3" FNPT	14.96 380	16.34 415	17.27 439
KVO-500 in. / mm	38.9 988	23.3 591	64.3 1633	20.3 515	16.42 417	3" FNPT	37.89 962	14.76 375	12.2 310	3" FNPT	19.96 380	19.01 485	20.1 510
KVO-700 in. / mm	38.9 988	27.01 686	67.05 1703	24.02 610	16.42 417	3" FNPT	39.82 1012	14.76 375	12.2 310	3" FNPT	14.68 500	19.73 501	20.1 510
KVO-900 in. / mm	42.8 1087	29.09 739	65.87 1673	27.52 699	16.54 420	3" FNPT	39.43 1001	19.53 493	14.76 375	4" FNPT	14.68 500	16.54 420	22.09 562

CONTACT US

For more information, contact your
 Regional Sales Manager or call us at:

1-800-825-6937

Your Local Sales Professional: